

Bulletin OIML n° 121

Décembre 1990

ISSN 0473-2612

BULLETIN

DE

L'ORGANISATION

INTERNATIONALE

DE MÉTROLOGIE LÉGALE

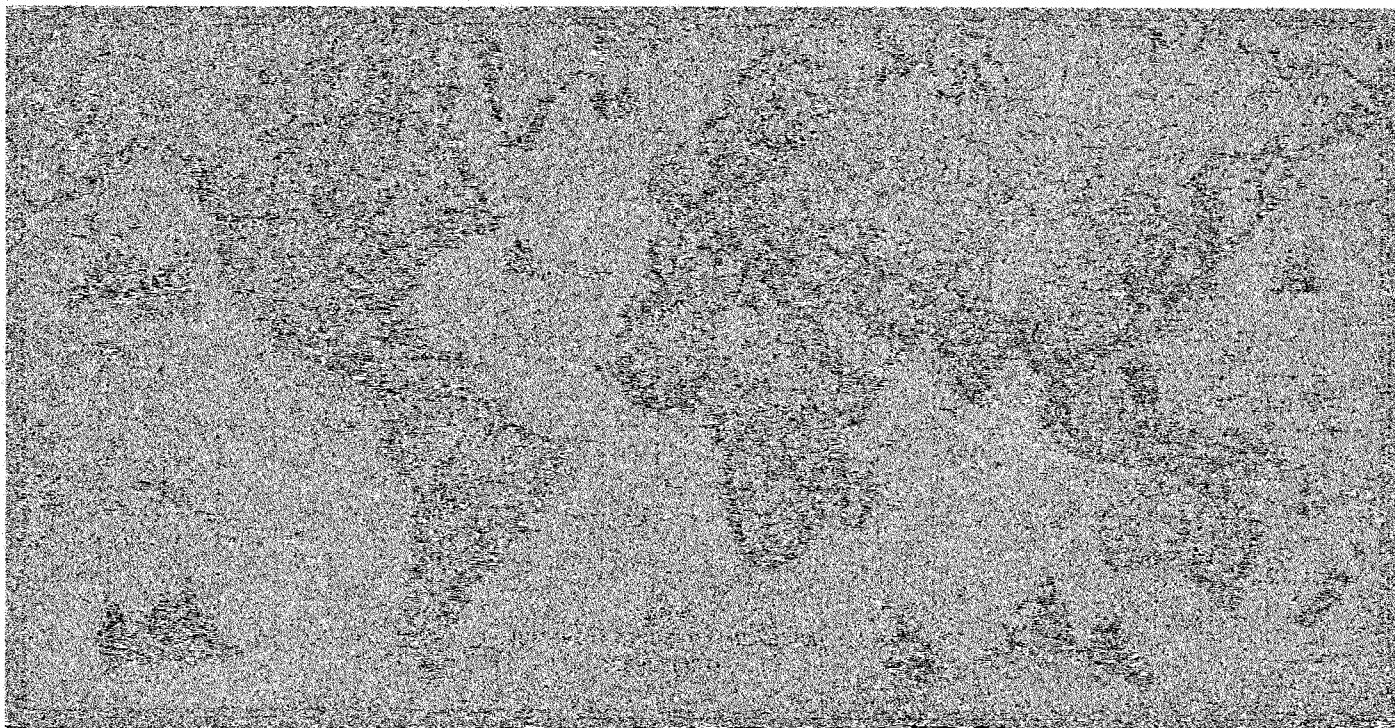
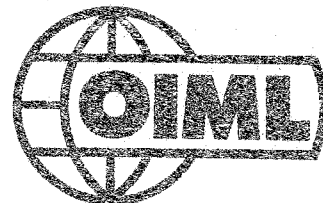

BUREAU INTERNATIONAL DE METROLOGIE LEGALE
11, Rue Turgot — 75009 PARIS — France

BULLETIN
de
L'ORGANISATION INTERNATIONALE de MÉTROLOGIE LÉGALE

SOMMAIRE

	Pages
25e Réunion du Comité International de Métrologie Légale	3
25th Meeting of the International Committee of Legal Metrology	5
ALLEMAGNE — Practical application of certain requirements in OIML R 76 "Non-automatic weighing instruments" by P. BRANDES	6
CHINE — The development of weighing instruments and the experiences and problems for applying R 76 in China by SHI CHANGYAN and SHI HANQIAN	20
ETATS-UNIS D'AMERIQUE — The weight classifier — Is there a place for it in R 76 ? by S. FEINLAND	25
FINLANDE — Gravity compensation of weighing instruments in Finland by T. LAMMI	31
ROYAUME-UNI — The impact of the gravity effect on weighing machines and metrological legislation by D.H. FEREDAY	39
ROYAUME-UNI — A new weighbridge test unit for Hampshire County Council by R.C. GOLDUP	47
European cooperation in the field of testing, EOTC and EUROLAB	50
INFORMATIONS	
Français/English	53
Quelques événements à venir — Some coming events	54
Réunions OIML/Meetings	55
DOCUMENTATION	
Publications: Liste complète à jour	56
Etats membres de l'Organisation Internationale de Métrologie Légale	63
Membres actuels du Comité International de Métrologie Légale	64
Adresses des Services des Membres Correspondants	69

Abonnement pour 1991 : Europe : 175 F-français
Autres pays : 230 F-français
Chèques postaux : Paris 8 046-24 X
Banque de France : B.P. 140-01 - 75049 Paris Cedex 01
Comptes Courants, Banques Etrangères, Cpte n° 5051-7

BUREAU INTERNATIONAL DE METROLOGIE LEGALE
11, Rue Turgot — 75009 Paris — France
Tél. 33 (1) 48 78 12 82 Le Directeur : Mr B. ATHANÉ
et 42 85 27 11 Téléfax : 33 (1) 42 82 17 27
Télex : SASVP 215463F ATTN OIML



VINGT-CINQUIEME REUNION DU COMITE INTERNATIONAL DE METROLOGIE LEGALE

Le Comité International de Métrologie Légale (CIML) a tenu sa vingt-cinquième réunion à Porto, du 3 au 5 octobre 1990, répondant ainsi à une invitation formulée par le Président de l'Instituto Português da Qualidade (IPQ) lors de la Huitième Conférence Internationale de Métrologie Légale en 1988.

La réunion du Comité a été officiellement ouverte par M. Luis Mira Amaral, Ministre de l'Industrie et de l'Energie, en présence de M. Candido dos Santos, Président de l'IPQ, de M. Mario Vicente, Vice-Président, de M. Antonio Cruz, Directeur de la métrologie à l'IPQ et d'autres personnalités portugaises dont le nouveau Membre du CIML, M. Cartaxo Reis. Une soixantaine de personnes représentant 37 Etats Membres de l'OIML y ont participé.

A côté de nombreuses décisions que l'on peut qualifier de routine (questions administratives et financières, activité du BIML, situation de certains Secrétariats techniques, etc.), le Comité a pris une décision que l'on peut considérer comme essentielle pour l'avenir de l'OIML: la création d'un Système de Certificats attestant la conformité de modèles d'instruments de mesure aux exigences formulées dans les Recommandations Internationales OIML concernées.

Ce Système va commencer à fonctionner dès 1991, sur une base très restreinte puisqu'il ne s'appliquera initialement qu'à quelques catégories d'instruments de mesure, en particulier les instruments de pesage à fonctionnement non automatique et les poids. Il est prévu que, année après année, ce Système s'élargisse à d'autres catégories d'instruments de mesure, au fur et à mesure que des Recommandations Internationales fixant les exigences métrologiques applicables à ces instruments, et décrivant les méthodes et moyens d'essai ainsi que le contenu du rapport d'essai, auront été publiées.

Le Comité a également adopté plusieurs nouvelles Recommandations Internationales, sur les cellules de pesée, les manomètres, les mesures de longueur à traits, les spectromètres à absorption atomique pour le mesurage de certains polluants et les analyseurs de CO/CO₂ pour les gaz d'échappement des véhicules.

Le Comité a enfin désigné un nouvel Adjoint au Directeur en la personne de M. A.S. Vishenkov, actuellement Chef de Service à l'Institut VNIIMS à Moscou; il prendra ses fonctions au BIML dans le courant de l'année 1991.

Tous les participants ont vivement apprécié la généreuse hospitalité des hôtes portugais et les à-côtés touristiques qui leur ont permis de visiter une cave de vin de Porto, ainsi que la petite ville de Guimaraes, berceau de la nation portugaise.

A l'issue des discussions, il a été décidé que la prochaine réunion du CIML se tiendrait à Paris du 7 au 9 octobre 1991, juste après la Conférence Générale des Poids et Mesures à laquelle beaucoup de Membres du CIML participeront.



Opening session of the 25th meeting of CIML.
From right to left the President of IPQ, the Minister of Industry and Energy,
the President of CIML and the Director of BIML.

TWENTY-FIFTH MEETING OF THE INTERNATIONAL COMMITTEE OF LEGAL METROLOGY

The International Committee of Legal Metrology (CIML) held its twenty-fifth meeting from the 3rd to the 5th October 1990 at Oporto, in response to the invitation extended by the President of the Instituto Português da Qualidade (IPQ) at the Eighth Conference on Legal Metrology in 1988.

The Committee meeting was opened officially by Mr Luis Mira Amaral, Minister of Industry and Energy, in the presence of Mr Cândido dos Santos, President of IPQ, of Mr Mario Vicente, Vice-President, of Mr Antonio Cruz, Director of Metrology at IPQ, and of other distinguished Portuguese personalities, including the new Member of CIML, Mr Cartaxo Reis. About sixty people representing thirty-seven Member States of OIML were present.

Apart from numerous decisions that might be called routine (administrative and financial matters, BIML's activities, the situation of certain technical Secretariats, etc.) the Committee took a decision that may be considered as essential to the future of OIML: the creation of a system for the issuing of certificates attesting the conformity of patterns of measuring instruments to the relevant OIML International Recommendations.

The System will start operation in 1991 on a very restricted basis, for it will apply initially only to a few categories of instruments, in particular to nonautomatic weighing instruments and to weights. It is expected that as the years go by the System will expand to include other categories of measuring instruments, as and when the International Recommendations specifying the metrological requirements applicable to those instruments, and describing the methods of test and the equipment required, as well as the contents of the test report, are published.

The Committee also approved a number of new International Recommendations, on load cells, pressure gauges, line measures of length, atomic absorption spectrometers for certain pollutants, and analysers of CO and CO₂ in vehicles' exhaust gases.

The Committee appointed a new Assistant Director of BIML in the person of Mr A. S. Vishenkov, currently Chief of the Department of International Cooperation in Metrology at VNIMS, Moscow. He will take up his duties during 1991.

All who attended appreciated greatly the generous hospitality of the Portuguese hosts, as well as the periods of relaxation in which they visited the little town of Guimaraes, cradle of the Portuguese nation, and sampled the delights of one of the famous Port wine cellars.

At the conclusion of the meeting it was decided that the next would be held in Paris from the 7th to the 9th October 1991, immediately after the General Conference on Weights and Measures, which many CIML Members will attend.

ALLEMAGNE

PRACTICAL APPLICATION of CERTAIN REQUIREMENTS in OIML R 76 " Non-Automatic Weighing Instruments "

by Peter BRANDES

Physikalisch-Technische Bundesanstalt

SUMMARY — This paper was read at the OIML seminar "Weighing in Braunschweig" 15-18 May 1990.

The author presents in a colloquial form various ways by which some of the requirements in the OIML Recommendation R 76 can be met in practical applications or by special constructional features of the weighing instruments. He treats in particular the subjects of

- Discrepancies in the metrological tests*
- Sealing*
- Alternatives for sealing*
- Multiple use of indication*
- Weighing instruments with built-in calibration weights*
- Weighing instruments with common bus line*
- Examination of the checking facilities upon pattern approval.*

Introduction

I should like to refer to several regulations in R 76, which may perhaps be differently interpreted by the various services of metrology. The reason is that the texts of the regulations often indicate only the aim but do not give any details how it can be reached.

To ensure that certain features of a weighing instrument are not assessed too differently, I should like to explain by examples how the PTB interprets some of these regulations.

At the beginning, however, I should like to discuss a metrological problem.

Discrepancies in the metrological tests

In the metrological tests we have often found minor discrepancies the cause of which is not yet known. These discrepancies lie within the maximum permissible errors but they are unsatisfactory and always leave an uneasy feeling.

In the temperature tests, changes of the sensitivity and also of the zero point are occasionally found. The temperature tests normally start at 20 °C, go over to 40 °C, — 10 °C, + 5 °C and finally return to 20 °C. In this cycle, a change of the zero point by several verification scale intervals and also a change of the sensitivity by up to one verification scale interval can take place.

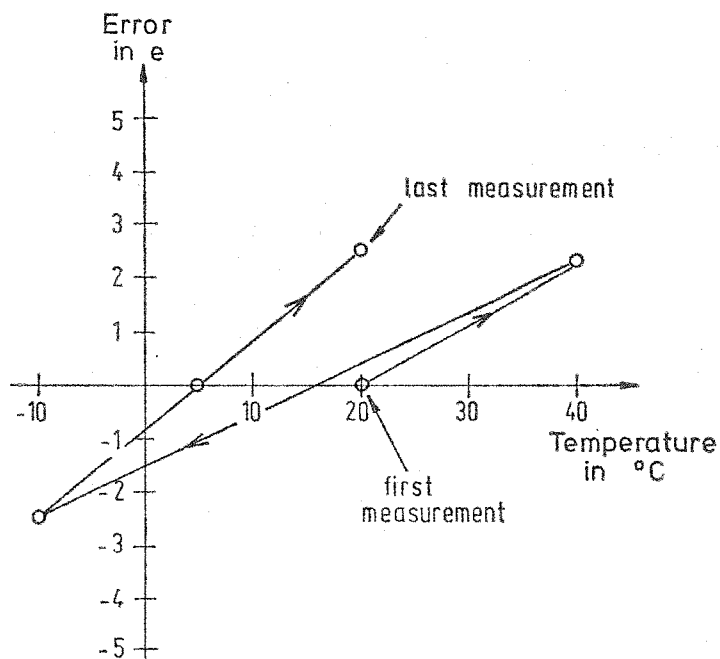

Fig. 1 — Temperature effect on no-load indication

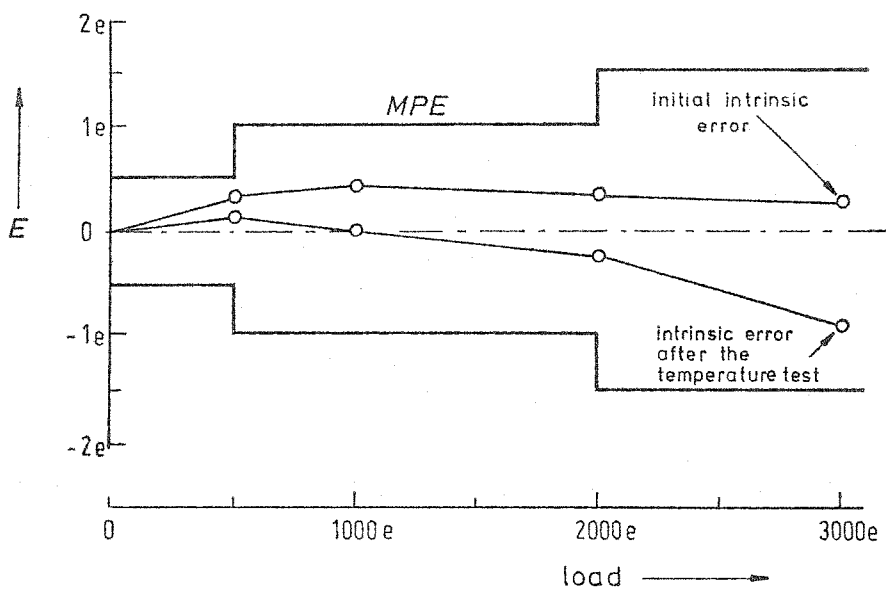

Fig. 2 — Intrinsic error at different times

Similar effects have also been observed when the instruments are switched off for some days between the tests.

These inconsistencies are to be found in particular with weighing instruments with a high resolution.

I would like to give some examples, first an example of the behaviour of the zero point in temperature tests (Fig. 1):

The test begins at 20 °C, goes over to + 40 °C, — 10 °C, + 5 °C and ends at 20 °C. It can be seen that here a change by 2.5 verification scale intervals has taken place.

This change of the zero point cannot be complained about, for there are only two requirements which must be met by the zero point:

- According to No. 3.9.4.2 of the R 76, the zero point is allowed to change by at maximum 0.5 e after the load has remained on the instrument for half an hour.
- According to No. 3.9.2.3, the zero point is allowed to change by at maximum one verification scale interval when the temperature has changed by 5 °C for instruments of the classes II, III and IIII.

I should now like to refer to the performance tests at various temperatures (Fig. 2):

Here, too, a change to the amount of one verification scale interval is observed after the temperature cycle.

I should like to point out that prior to the temperature tests, such changes were generally not observed during the tests which lasted several weeks. Hardly any changes occurred after the temperature test. Occasionally, changes were found after the instruments had been switched off for several days or weeks and were again put into operation.

As far as these changes are concerned, it is hardly ever possible to find out whether they are time — or temperature — dependent.

In our opinion, changes of the zero point are not so important as long as non-automatic weighing instruments are concerned and the zero point can always be re-adjusted by the user.

Properly speaking, changes of the sensitivity should not occur. However, they cannot be complained about if they are within the maximum permissible errors. However, one can never be sure that similar effects which are possibly even stronger, will occur during the several years of use of the instruments, and here effects may be concerned which cannot be detected during the relatively short period of time required for our tests.

I assume that some of you, too, have occasionally observed these changes and discrepancies during the tests carried out in your laboratories.

In these cases, we usually contact the manufacturer to find the reasons. It is true that the reason cannot always be found, but sometimes the respective weighing instruments are improved in one way or the other.

Table 1 — Changes of the sample instruments during the total test period

	Changes found	Permissible changes
zero point	up to 5 e	no prescription
span	up to 1 e	maximum permissible errors (mpe)

Sealing

As one of the general requirements relating to the design and construction of weighing instruments, No. 4.1.2 of R 76 mentions the security. Concerned are regulations concerning

Fraudulent use	No. 4.1.2.1
Accidental breakdown and maladjustment	No. 4.1.2.2
Controls	No. 4.1.2.3
Sealing	No. 4.1.2.4
Calibration	No. 4.1.2.5

First, I should like to refer to the sealings. In another part of my paper, I will discuss acceptable alternatives and the calibration of weighing instruments.

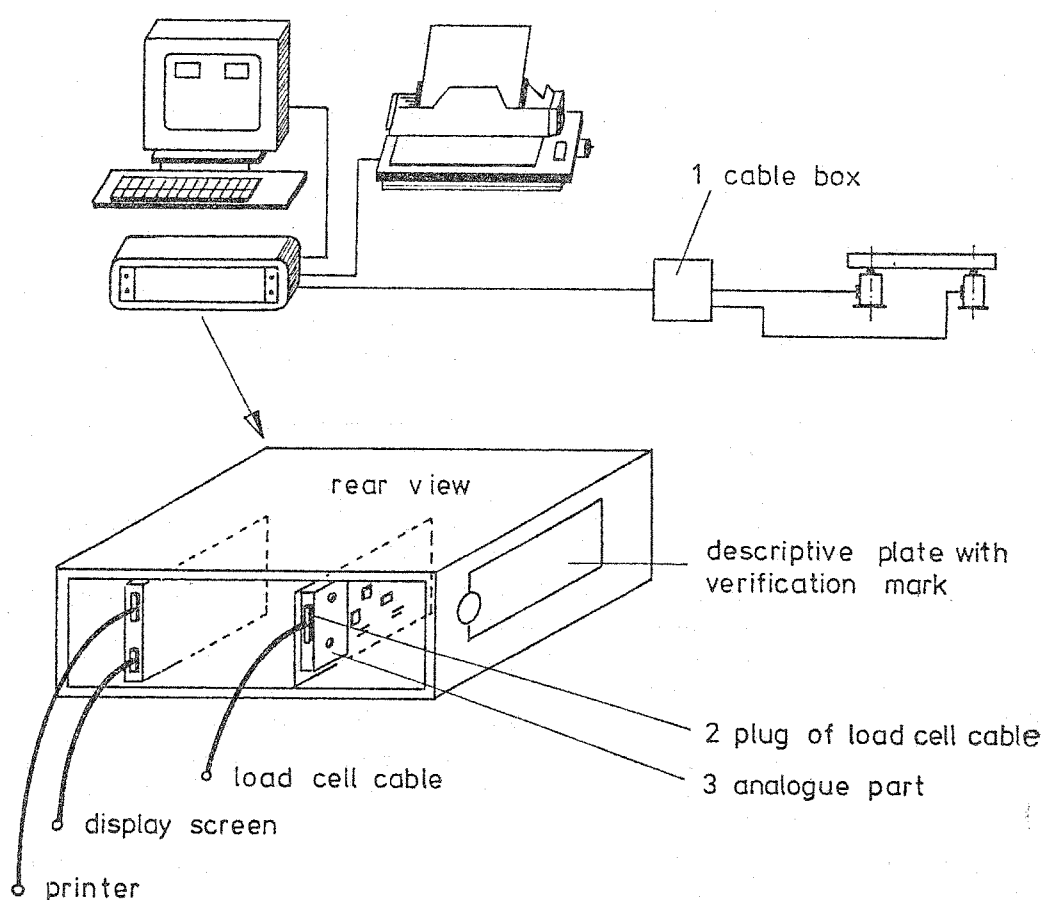

required	not required
1. cable box	— interface screen display
2. plug of load cell cable	— interface printer
3. adjusting elements in analogue part, memories (EEPROM) with relevant metrological data	— digital part incl. program memories
	— power supply unit
	— keyboard

Fig. 3. — Sealing

According to No. 4.1.2.4 of the R 76, certain components must not be dismantled or adjusted by the user without evidence that such an event has occurred.

I will now explain by an example, which parts of an electromechanical weighing instrument must usually be protected.

The figure shows the typical set-up of such a weighing instrument equipped with a screen display unit and a printer.

Almost all load cells are equipped with a fixed cable terminal which cannot be removed. The cable is first led into a so-called cable box which allows several load cells to be connected. This box must be sealed to protect it against opening as here eccentricity adjustment takes place.

One cable runs then from the box to the electronic indicator. A plug is used to connect the cable to the input of the analogue part. This connection, too, must be protected against removal since false measurement values will be obtained if wrong or other load cells or weighing platforms are connected.

In the figure 3, the analogue part is protected against exchange and made inaccessible by a cap which in turn is protected against dismantling.

This cap also covers the adjusting potentiometer and the EEPROM (Electrical Erasable Programmable Read Only Memory) containing the parameters and factors specific to the respective weighing instrument. These components, too, must not be accessible to the user, since false measurement values can be formed when the potentiometer is wrongly adjusted or the parameter memory exchanged.

All other parts of the electronic indicator need not be sealed. Concerned are the power supply unit, the complete digital part including program and data memories, the indicating device, the electronic device to control the printer, and the connections for the display terminal and the printer. This means that the manufacturer may carry out repairs of these components without subsequent verification being necessary.

No protection against exchange is required for the program memory (EPROM) since this memory contains only the program of the measuring procedures and the measurement values cannot be influenced when the correct programs are used.

Basically, this can be compared with the knives and bearings of a mechanical weighing instrument. If wrong knives and bearings are substituted for them, the transmission ratio may change and false values are indicated.

The manufacturer is solely responsible for the installation of the proper knives and bearings or of the proper program memories.

The above explained sealings are minimum requirements. At the manufacturer's request or in cases where another solution is not possible, the housing of the weighing instrument as a whole can be protected against opening.

Spaces for marks are provided on the housing of the display screen and on the separate keyboard in order that it can be demonstrated that these devices have been included in the verification.

The place for the mark of conformity should be provided on the descriptive plate. The plate is then protected against removal.

Finally, I should like to describe a special way of connecting parts of a housing, which in our opinion can be compared with riveted or welded joints since opening is only possible when the connection is destroyed (Fig. 4).

In this case, connection is ensured by pull-off screws.

Prerequisite for the use of pull-off screws is that

- they are sunk in and
- cannot be screwed out with a normal or a special tool.

If these conditions are fulfilled, the connections are considered to be "fixed connections" and the sealing can be dispensed with.

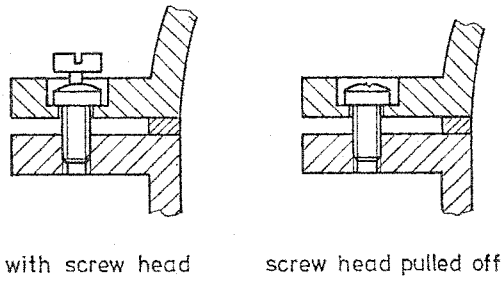

with screw head

screw head pulled off

- pull-off screw
- screw head sunk in
- shall not be screwed out with a special tool

Fig. 4 — Protection by pull-off screw

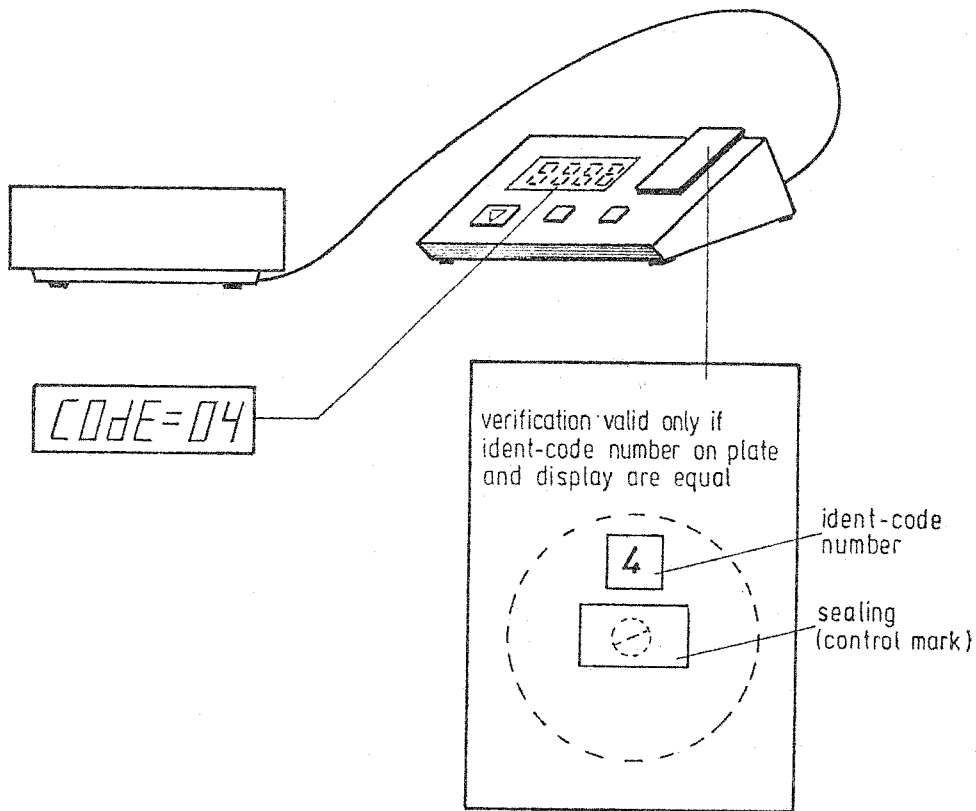

Fig. 5

Alternatives for sealing

I now come to a specific solution for a sealing which can be considered as an acceptable solution.

As I have already pointed out, point 4.1.2.4 of the R 76 does not permit the user to remove or adjust certain components without evidence that such an event has occurred.

Among these certain components are counted above all the adjusting devices which in the past had always to be protected against maladjustment by a seal. When the seal was broken on the occasion on an adjustment, this was perceived by everybody, and the verification was no longer valid.

By the example of a weighing instrument, I should like to show you another possibility of protecting an adjusting device. This weighing instrument consists of a platform with incorporated load cell and electronic device and a separate display and operator terminal (Fig. 5). The measured values are completely formed in the platform and digitally transmitted to the display terminal.

The manufacturer has applied for the weighing instrument being adjusted by the service staff without a safety seal having to be broken. This procedure is possible when the service mode which is of a somewhat complicated access is used in connection with the standard keyboard of the weighing instrument. This procedure is normally provided only for the customer service but a skilful operator would be able to adjust the weighing instrument by this method.

According to the regulations, such features of the weighing instrument should not be permitted.

How can fraudulent use be prevented ?

The manufacturer of the weighing instrument has taken some measures which allow adjustment to be clearly recognized:

Every time an adjustment has been carried out, a counter in the electronic device in the platform progresses by the value 1. This counter cannot be changed nor zeroed and, what is more, it is not accessible because it is accommodated in the sealed housing of the load cell.

The count can be displayed on the terminal; for this purpose, a key must be pressed. This count which is referred to as ident-code is also adjusted on a dial on the descriptive plate and thus can be seen by the operator of the weighing instrument. This dial is protected against false adjustment by a sealing. As a consequence, once an ident-code number is adjusted, it cannot be changed unless the seal is broken.

The descriptive plate also contains the information that the verification will no longer be valid if the ident-code numbers are not identical.

As long as the two "ident-code numbers" on the descriptive plate and in the display are identical, everything is all right.

When an adjustment is carried out, the count value increases and the ident-code numbers are no longer the same. This means that the verification is no longer valid.

In our opinion, this kind of protection can be compared with a complete sealing of the whole housing. As with a normal stamping area or seal, it is possible at any time to check the ident-code number.

The responsibility now lies again with the weigher. When he detects that the ident-code numbers do not agree, he must no longer use the weighing instrument just as if the seal were broken.

Multiple use of indicating devices

(displays qualified/not qualified for verification)

According to No.4.4.2 of R 76, an indicating device may display information other than only the weight value. This other information or these other values are not subject to mandatory verification. It must, however, be ensured that

- indicated quantities or values which are no weight values are identified by the appropriate unit of measurement, or symbol thereof, or a special sign,
- indicated weight values which are no weighing results in the sense of this Recommendation, are either clearly identified or are displayed only temporarily on manual command and must not be printed.

The Table 2 shows some examples of such values and the respective identifications:

Quantities which are no weight values are displayed together with the respective sign, i.e. percent, piece or °C. It can be directly read which quantities are concerned.

It is also possible to use special symbols or signs for identification. In the example, I have used individual segments of a normal 7-segment display. The disadvantage of this way of identification is, however, that it is not at once clear from the sign which quantity is concerned. The requirement is, however, met: the displayed value cannot be confused with the weighing results.

The next example shows weight values which are not, however, weighing results. They are either identified by an additional explanation (in the example: "REF" for reference mass) or simply by an additional symbol (asterisk, circle).

These additional symbols must be explained in the instruction manual; this is a rule at present applied at the PTB. Any weight value identified in this way may be displayed. This may be, for example:

- weighing results calculated with a factor
- particle masses, reference masses
- sums of individual weighing results

Table 2 — Displays other than weight

Displays	Identification by	Example
Any quantity and value (no weight value)	appropriate sign	123,4 % (percent) 1234 Pcs (number of pieces) 22 °C (temperature) 1234 ≡ 123,4
Weight values (no weighing results)	clear identification tempory display on manual command	REF 1,234 g (reference mass) 123,4 g* (any value) 0 123,4 g (any value) 1,234 g ("REF" key for reference mass)
Any display	none	weighing mode switched off — — key and light-emitting diode — large lever with inscription — luminous letters —

- weight values derived from weighing results
- weight per volume
- mass per area etc.

When — upon manual command — the respective value is displayed only temporarily for a certain period of time (approx. 2 to 3 seconds), no identification is required. The command key must in this case be appropriately marked.

For reasons of clarity, weight values which are not weighing results should always be displayed together with the unit symbol g, kg or t. Numerical values alone should only be indicated during their input via the keyboard.

If such values are printed, they should be identified as in the display.

According to No. 4.4.2, the above examples and the respective identifications are not applicable if the weighing mode is made inoperative by a special key. In this case, any quantity and value may be displayed and its identification can be freely chosen by the manufacturer.

What is not quite clear is how the weighing mode is to be made inoperative and how this regulation is to be interpreted.

Do a simple change-over key and a small light-emitting diode pointing to the respective mode suffice, or should a large change-over lever provided with an inscription be used or should illuminated letters point to this mode of operation?

It should, however, be quite clear that quantities derived from weighing results, such as number of pieces, percent etc. must not be displayed in this mode of operation, as in this case the indication changes as a function of the load and it looks as though the "weighing instrument" is still operative.

Weighing instruments with built-in calibration weights

The resolution of the electronic weighing instruments presented for approval is increasingly higher, which results in ever higher requirements having to be met by the materials and components used in the instrument.

There are, however, certain limits: It is, for example, not easy to procure suitable electronic components with sufficient long-term stability for high-resolution weighing instruments. This shortcoming can naturally adversely affect the stability of these weighing instruments when they are used over a prolonged period of time. The potential impairments or instabilities are to be attributed to the electronic system and in part also to the mechanical structure of the weighing instruments and often cannot be coped with and controlled without great design and manufacturing efforts. It therefore suggests itself to readjust these weighing instruments at short intervals of time. This would all at once solve the above-mentioned problems, and the weighing instrument would always indicate correct weighing results.

According to No. 4.1.2.4 of R 76, such an adjusting device is normally not permitted. There are exceptions only for class I weighing instruments and according to No. 4.1.2.5 for weighing instruments in which a weight is built-in for calibration. An external influence on the calibration device must, however, be practically impossible.

What is meant by this regulation? This formulation is intended to make calibration possible but to prevent the weighing instrument from being incorrectly calibrated on purpose and, as a result, indicating wrong weighing results.

It would, for example, be conceivable that during calibration an additional weight is intentionally put on the load receptor with a view to bringing about a false adjustment. Preclusion of this undue intervention would, however, require a great complexity of the mechanical design of the weighing instrument. It would be necessary to mechanically decouple the load receptor from the load cell.

In the PTB's approval practice, a procedure has developed which allows this complex mechanical solution to be avoided. This problem has been solved by various checks and inquiries in the program flow of the microprocessor system:

- (1) The calibrating operation takes place automatically upon manual command.
- (2) Before the calibrating weight is placed, the zero point is checked.
- (3) The built-in calibration weight is placed automatically.
- (4) Inspection and, if necessary, calibration of the weighing instrument.

For class II weighing instruments, calibration may be carried out in a total range of 100 verification scale intervals, and for classes III and IIII weighing instruments, in a total range of 10 verification scale intervals.

- (5) No display of any values during calibration. In our opinion, this is a very important aspect because otherwise the user would know the value of the calibration weight and it would be less difficult for him to tamper with the weighing instrument.
- (6) Removal of the calibration weight.
- (7) Recheck of the zero point.
- (8) There will always be an error message if the zero point has changed or if the calibration range of $10e$ is exceeded. By this range a total range is to be understood which is defined, for example, on verification or on initial calibration and stored in the weighing instrument. Calibration can then take place in this total range of, for example, $\pm 5e$. If this range is exceeded because several calibrations are carried out, an error message must appear.

In our opinion, these restrictions make essential calibration errors impossible so that the complex mechanical decoupling of the load receptor can be dispensed with. The operating instructions must inform the user that the weighing instrument remains unloaded for and during calibration.

Other solutions to prevent external influence on the calibration device are naturally conceivable. But this procedure has proved its practical worth for several years, and we have not heard of any complaints by users or verification authorities.

Weighing instrument with common bus line

A weighing instrument consisting of several modules has recently been presented to us for pattern approval. These modules were the platform, the display and operator terminal and the printer. They were connected by cables (Fig. 6).

The measured values are formed in the platform from where they are digitally transmitted via the interface either to the display terminal or to the printer. The devices are connected to a common bus line; every device connected can independently transmit and receive data.

Such a configuration is in itself nothing particular providing the leads connecting the devices are permanently interconnected; by this, I understand sealed leads and plugs. The system would thus be a closed one, the components could not be exchanged, and it would not be possible to influence the system from the outside. The respective regulations for the security of the weighing instrument as they are contained in No. 4.1.2 of the R 76 would be obeyed.

But now the manufacturer has filed an application requesting that

- none of the plug and socket connections of the bus line are sealed so as to make the exchange of components possible;
- it will be permitted to connect other devices not subject to mandatory verification to the common bus line. These might be, for example, external data processors or personal computers for internal purposes.

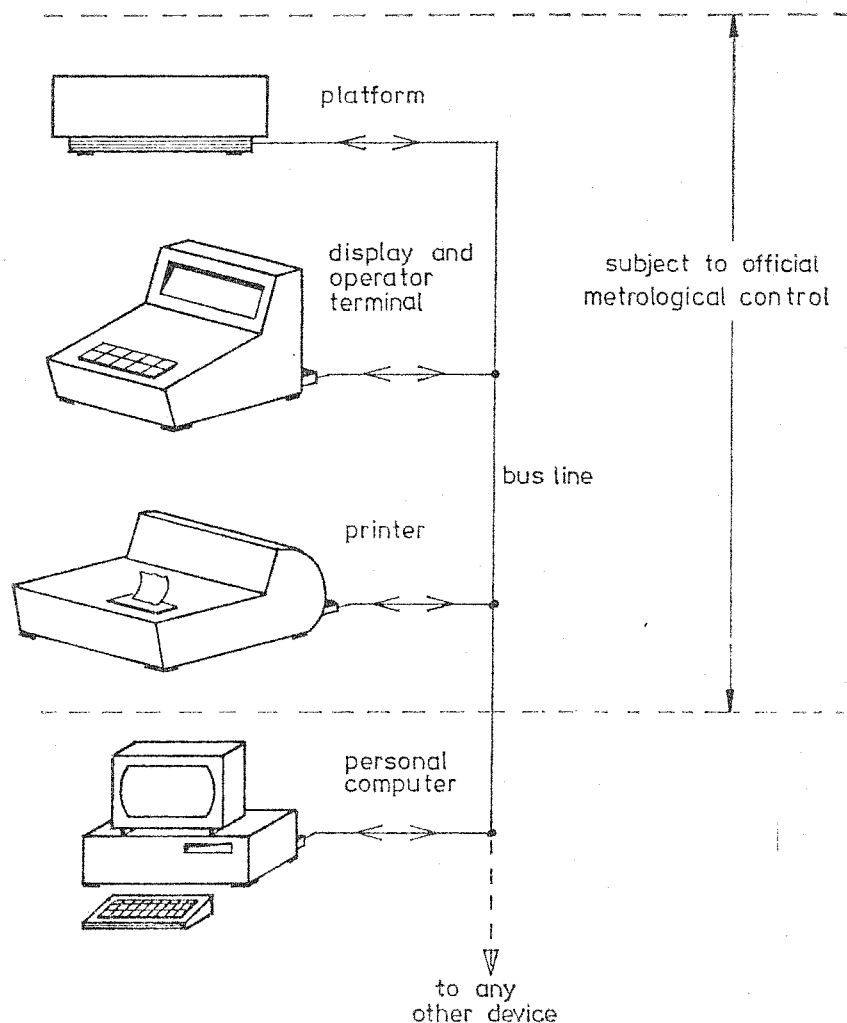

Fig. 6 — Interconnection of modules

The common bus line system of the weighing instrument would, thus, be accessible, and in addition to the components forming part of the weighing instruments, other — optional — devices could be connected. As a result, it would be conceivable that influences are exerted on the weighing instrument. For in the place of the platform of the weighing instrument, a computer might transmit weight values via the common bus line to the display terminal or printer without this being noticed. As a consequence, the readings or printouts would be false, and fraudulent use would not be difficult at all.

Of course this potential manipulation or influencing of the measuring system or weighing instrument is inadmissible, therefore such a pattern could not be approved straight away.

In order to prevent potential tampering and manipulation, the manufacturer has provided some protective features. These refer to both the data to be transmitted and the possible manipulations or influences to be prevented:

- (a) Data records with different check sums.
- (b) Each data record with one byte specifying its total length.

- (c) Each data record is retransmitted to the transmitter for checking.
- (d) Forming of a check sum using special codes developed by the manufacturer and decoding in the receiving module.
- (e) Every module checks the addresses of all data records. In the case when its own address appears though the module has not transmitted this data record an error message will be generated, as this data record can only be manipulated by a device which is not part of the weighing instrument.

A computer controlled automatic trial and error input of manipulated data records on the common bus line can also be precluded, as any detected manipulation attempt leads to an error message and blocking of the weighing instrument. The error message can be cancelled only by manually switching off and on the weighing instrument. Due to the necessary switching-off and on, such a manipulation would take very much time and is therefore not taken into consideration.

In our opinion, these features are completely sufficient to ensure protection of the weighing instrument with an open common bus line system against manipulation. The correctness of the data transmitted is also ensured by the other features.

In the end, pattern approval was granted for this weighing machine.

Examination of the checking facilities upon pattern approval

No. 5.1.2 of R 76 requires for electronic weighing instruments that

- durability shall be proved by special tests or that
- durability protection features shall be provided.

In the following, I should like to refer only to the durability protection features and in particular to the checking of these as part of the pattern approval test.

The application for pattern approval must be accompanied by documents. According to No. 8.2.1.2 of R 76, these documents are in particular:

- drawings of the general arrangement and details of metrological interest,
- a brief functional description of the instrument,
- technical descriptions of the method of operation in particular for the checking facilities and durability protection features, including, if necessary, schematic diagrams.

To be able to carry out the approval test correctly and completely, we require the following documents relating to the design of the electronic system:

- Precise description of the functions incorporated in the instrument. Concerned are, for example, the sequences for zero setting, automatic zero tracking, taring, input and output possibilities via the interfaces, accessibility and function of the adjusting device, functions of and inputs by means of the keyboard, possible displays, and similar.
- A block diagram of the electronic system which allows interrelations to be recognized.
- Exact circuit diagrams of all parts of the electronic device involved in the determination of the measurement values. In these diagrams, the electronic components must be clearly identified, i.e. technical data and type must be specified.
- Descriptions of the function of analogue and digital part. The functional sequences in the electronic system are to be described. Reference should in particular be made to the determination and processing of a measurement value from the moment it enters the electronic system until it is put out or displayed.
- Detailed descriptions of the built-in checking facilities for controlling durability.

All features provided are to be described in detail. I should like to demonstrate by two examples how this description should be drawn up in our opinion.

Analogue part: After actuation of the "Test" key, the electronic switch ES 1 cuts off the measurement voltage of the load cell. By means of ES 2, a test voltage is applied to the input of the first amplifier. By means of resistors R 12 and R 13, the test voltage is taken from the separate reference voltage element D 7. In this case, the analogue part is modulated to up to 90 %. A test number is shown in the display, which amounts to about 90 % of the weighing instrument's maximum capacity.

Digital part: Test of the parameters and factors specific to the weighing instrument and contained in EEPROM:

- > Storage of the data with one parity bit per byte and with a longitudinal check sum covering all bytes.
- > After switching-on, complete check of all data required to determine the measurement value. Comparison of the longitudinal check sum with a stored reference check sum.
- > Check of the parity bit of part of the data. EEPROM is completely checked after 32 measurement cycles. This takes about 20 seconds.

Each of these checks in the analogue and digital part must be described in this way. Additional flow charts may be enclosed, however, they are not demanded explicitly.

In exceptional cases or if necessary, the manufacturer may be asked to submit additional descriptions or supplements. These may be excerpts from the program listing in order that sequences and test routines can be understood. This is not at all easy as it presupposes good programming knowledge. In my opinion, checking of the listing should only refer to the availability of test routines and should be made by spot checks in the presence of the design engineer.

We should therefore confine ourselves to the description referred to above. This description must, however, be comprehensive.

- Only the features described will be permissible. Additional features in the weighing instrument's function and in the test circuits, which have not been described, will not be permissible and must not be provided.
- By the above description, the manufacturer guarantees that the checks are made in the way described and as frequently as stated and that the checking facilities are actually incorporated in the weighing instrument.

This way of proceeding has several advantages:

- It is absolutely unimportant in which part of the program memory or program flow these test routines are provided.
- Any additional program may be provided unless it influences the determination and processing of the measurement values.
- Program listings may not be checked.
- It is not necessary during the pattern approval test to actually read out the program memories by using very special and expensive equipment and to compare them with the listings as this way of proceeding would require specially trained staff.
- And last but not least, the test is relatively simple.

I should like to emphasize once more: Solely the manufacturer is responsible for the described program features being provided in the weighing instruments for the determination of the measurement values. If other sequences or functions are in-

cluded which have not been described, the weighing instrument does not comply with pattern approval.

This way of proceeding has the advantage that we must no longer consider any inadmissible sequences or functions possibly hidden in the program. The manufacturer may submit for verification only such instruments which agree with these descriptions.

In addition, No. 5.3.6 of R 76 requires that the presence and correct functioning of durability protection features be checked.

In the analogue part, this is relatively easy since some additional components will always be necessary to generate a test voltage. It can easily be checked whether or not the respective components have been included in the printed circuit card.

Correct functioning can also be easily checked by operating the "Test" key. The displayed test number must comply with the stored reference input within the permissible tolerances.

If the analogue part is checked automatically, there is still the relatively simple possibility of falsifying the test voltage at the above-mentioned resistors, for example, by soldering a shunt resistor. The checking facility must now respond and indicate an error. The presence and correct functioning of the checking facility would then be definitely proved.

Many different checks are carried out in the digital part which comprises a microprocessor system. Various areas must be checked, such as counter, multiplexer, program memory, data memory, microprocessor, input-output chips etc. Added to this are all 8 or 16 data or address lines of the microprocessor.

A lot of checks are therefore incorporated. They usually are carried out inside the microprocessor system and are no longer accessible from the outside. In view of the numerous possibilities, error simulation as described for the analogue part could never be carried out completely in the digital part and would not, therefore, be reasonable.

We therefore suggest that the existence of checking facilities be proved only on the basis of the documents submitted. If necessary, submission of additional documents, such as program listings, may be requested and the designer of the electronic system may provide additional information.

CHINE

The DEVELOPMENT of WEIGHING INSTRUMENTS and the EXPERIENCES and PROBLEMS for APPLYING R76 in CHINA *

by Shi CHANGYAN and Shi HANQIAN
National Institute of Metrology

SUMMARY — This paper deals with the current state, aims and means in the field of the weighing instrument development in China, and gives a description about the application of the OIML International Recommendations to the weighing instruments, especially about the experience and problems in working out or revising the regulations concerned and in conducting the pattern approval for new types of products in recent years.

The national regulations of metrological verification and the national standards worked out or revised in China referring to the International Recommendations are also listed.

1. The Current Situation of Development of Weighing Instruments

The uniformity of weights and measures regulations in China can be traced back to the Qin Dynasty (221-207 B.C.). Nowadays the most recent complicated electronic weighing instrument designs, for example automatic belt-conveyor scales are used at the same time as the traditional simple mechanical weighing instruments, as for example steelyards. It is a common situation in developing countries we believe.

Statistics supplied by China Association for Weighing Instruments concerning the annual output in 1989 is summarized in Table 1. Among 1 635 000 sets of (A), (B), (C) Types of weighing instruments, there are about 1.4 % or 23 000 sets of electronic instrument including 17 000 sets of price-counting scales produced by 14 manufacturers and 6 000 sets of industrial weighing instruments produced by more than 40 manufacturers, out of which 18 manufacturers produce continuous totalising automatic instruments, 17 manufacturers produce crane scales, 5 manufacturers produce automatic rail-weighbridges and only a few produce discontinuous totalising automatic instruments.

Table 1 — Annual Output of Weighing Instruments in 1989

Type of weighing instrument	Annual output	Quantity of manufacturers
(A) Heavy type of industrial weighing instruments	25 000	48
(B) Middle and small types of industrial or special weighing instruments	210 000	
(C) Daily use type of commercial weighing instruments	1 400 000	100
(D) Steelyard for retail (non-self-indicating)	7 000 000	150

* Presented at the OIML Seminar "Weighing in Braunschweig" 15-18 May 1990.

Manufacturers engaged in production of electronic weighing instruments amount to nearly 70 by the end of 1989. Among 1 635 000 sets of (A), (B), (C) type of instruments, there are about 7.5 % or 123 000 sets of self-indicating weighing instruments including 100 000 sets of dial spring scales and 23 000 sets of electronic instruments.

The weighing instrument industry has the goal to attain in the next five years:

- gradual elimination of a great deal of steelyards and reducing lever type mechanical weighing instruments;
- development of a more widespread use of electronic weighing instruments, dial spring mechanical scales and hybrid electromechanical weighing instruments;
- steady increase of the annual output from 1.6 million to 2.1 million among which 40 % of them are self-indicating weighing instruments and 11.4 % are electronic weighing instruments.

2. Application of OIML R 76 to National Metrological Verification Regulations and National Standards

For a long time, there was no accuracy classification of non-automatic weighing instruments for new product, after-repair or in-service in China. In 1950's, the GOST Specifications of USSR were introduced and used. In 1960's, verification regulations for five sorts of non-automatic weighing instruments such as bench scale, platform scale with beam counter poise, pit scale, dial scale and steelyard were elaborated after considering the domestic status. As a reference example, former maximum permissible error for lever type of bench, platform and pit scale is listed in Table 2.

Table 2 — Former MPE Requirement for Lever Type Scales

State of scale	Maximum Permissible Error		
	no load	(1/20-1/5) Max	(1/5-1) Max
new product after-repair	1/10000 Max	1/10000 Max	1/2000 actual load
in service	1/10000 Max	1/5000 Max	1/1000 actual load

Since a Chinese delegation participated in OIML Conferences as observer for the first time in 1981 and became member of OIML in 1985, we began to learn about R 3 and R 28 and try to apply them to work out or revise National Metrological Verification Regulations. Referring to the basic content of the OIML relevant International Recommendations, JJG1003-84 "Accuracy Classes of the Non-Automatic Scale" was issued for promoting adoption of the Recommendations.

Non-automatic scales are divided, according to verification scale interval e and number of interval n , into three classes in which high accuracy instruments are used for weighing valuable goods or as reference standard, and medium accuracy instruments are used for general trade, and ordinary accuracy instruments are used as coarse scale weighing low valuable goods (Table 3).

Table 3 — MPE Requirement for Non-Automatic Scales

Load			MPE	
Class II	Class III	Class III	new product, after-repair	in service
0-5000 e	0-500 e	0-50 e	± 0.5 e	± 1 e
5 000e-20 000 e	500 e-2 000 e	50 e-200 e	± 1 e	± 2 e
20 000 e	2 000 e	200 e	± 1.5 e	± 3 e

Customarily speaking, weighing instruments can be divided into scales and balances in general, and almost all special accuracy instruments belong to balances.

It seems to be a serious problem in China that more than 100 million sets of steelyards of ordinary accuracy are widely used in the countryside market. The consumers protection sometimes sustains losses. For that historical and technical reasons, efforts will be made to develop the mechanical or electronic self-indicating weighing instruments instead of the traditional steelyards.

When R 76 is to be applied to our National Metrological Verification Regulations, sometimes certain relevant requirements are modified or released temporarily to suit the need of development of domestic-built scales. For instance, the crane scales by which goods are weighed in the quasi-static condition, are divided into two accuracy classes as follows (Table 4).

Table 4 — MPE Requirement for Crane Scales

Load (m)		MPE	
Class A	Class B	new product, after repair	in-service
$0 \leq m \leq 500 e$	$0 \leq m \leq 50 e$	± 1 e	± 1.5 e
$500 e < m \leq 2 000 e$	$500 e < m \leq 200 e$	± 1.5 e	± 2 e
$2 000 e < m \leq 10 000 e$	$200 e < m \leq 1 000 e$	± 2 e	± 3 e

Number of verification scale interval n shall be larger than 1 000 for the class A. A large part (about 3/4) of the National Metrological Verification Regulations are listed in Table 5 and National Standards in Table 6:

Table 5 — National Metrological Verification Regulations of Weighing Instruments

Code No.	Name of Verification Regulation
JJG 1003-84	Accuracy Classes of Non-Automatic Scales
JJG 9-86	Person Weighers
JJG 13-86	Dial Scales
JJG 14-85	Movable Lever Scales
JJG 16-87	Fixed Lever Scales
JJG 17-86	Steelyards
JJG 46-76	Torsion Balances
JJG 98-72	Balances
JJG 142-87	Static Rail-Weighbridges
JJG 156-83	Top-pan Balances
JJG 171-85	Hydrometric Balances
JJG 195-79	Roll Belt Scales
JJG 216-87	Mechanical-Electronic Scales
JJG 234-81	Dynamic Rail-Weighbridges
JJG 391-85	Load Cells
JJG 426-86	Optical Grating Scales
JJG 444-86	Master Rail-Weighbridges
JJG 460-86	Static Mechanical Rail-Weighbridges with Grating-digit
JJG 510-86	Electronic Crane Scales
JJG 539-88	Price-computing Scales
JJG 560-88	Cantilevered Electronic Belt Scales
JJG 564-88	Mechanical Quantitative Scales
JJG 565-88	Electronic Quantitative Scales for Bulk Grain
JJG 578-88	Bench Spring Dial Scales
JJG xxx-89	Digital Weighing Indicators
JJG xxx-90	Continuous Totalising Automatic Weighing Instruments
JJG xxx-90	Discontinuous Totalising Automatic Weighing Instruments

Table 6 — National Standards of Weighing Instruments

Name of Standards
Type AGT Bench Scale
Type TGT Platform Scale with Beam Counter Poise
Type SGT Floor Weighbridge
Type IGT Pit Scale
Type ACS Electronic Price-Computing Scale
Type OGT Tram Weighbridge
Fixed Electronic Scale
Electronic Belt Scale
Electronic Hopper Scale
Basic Specification for Weighing Indicator and Controller
Packing Specification for Daily Use Type of Commercial Scale

3. Requirements from the Law on Metrology, and Testing of Electronic Weighing Instruments for Pattern Evaluation

According to the Law on Metrology of P.R. China entered into force on July 1, 1986, weighing instruments of any kind used in trade accounts, in safety protection, in medical treatment and health and in environmental monitoring shall be subject to compulsory verification by the authorities responsible for legal metrology above county level. Those weighing instruments which have not been submitted for the verification provided for by the regulations and those which have been checked as unqualified, shall not be used.

Imported weighing instruments may be marketed only after they have been verified or tested and found to be up to standard by the authorities above province level. Many kinds of foreign products have passed such verification or test.

Any enterprise or institution engaged in manufacture or repair of weighing instruments shall have appropriate facilities, personnel and verification equipment, and may after being proved as qualified by the authorities above country level, obtain the "Licence for Manufacture of Weighing Instruments" or "Licence for Repair of Weighing Instruments". From 1986 up to now, about 149 manufacturers obtained such licence for manufacture in our country.

Where any enterprise or institution manufactures new types of weighing instruments which have not been manufactured by themselves before, the new types of weighing instruments may be put into production only after the metrological performance of specimens have been proved as qualified through technical evaluations organized by authorities above province level.

On the principle of Annex A and B of R 76, we have worked out the domestic testing procedures for such pattern evaluation of non-automatic electronic weighing instruments.

In addition to the tests for dry heat and cold, power voltage variations, short time power reductions, electrostatic discharge, electromagnetic susceptibility, transients disturbance, steady state dry and damp heat, the following five test items are proposed to be conducted:

- (1) Windspeed test — The indication of the EUT shall not vary when wind blows out at speed of 2.5 m/s.
- (2) Mechanical vibration test — In the frequency range of 2-3 000 Hz, find the resonance point of the EUT by means of sweeping at rate of 1 or less than 1 frequency multiple/min; Keep 5 minutes at this resonance point; Change frequency and acceleration, and then record the data when indications of the EUT vary 1 e.
- (3) Mechanical shock test — Three faces of the EUT with package are shocked individually under half-sine wave with an acceleration of 15 g and pulse duration of 6 ± 1 ms.
- (4) Magnetic disturbance test — Expose the EUT to magnetic field with strength of 60 A/m.

Considering the high testing costs, the test of some items in Annex A and B of R 76 may be simplified according to the practical situation.

The WEIGHT CLASSIFIER - Is there a place for it in R 76 ? *

by S. FEINLAND

Pitney Bowes Inc., Shelton, CT, U.S.A.

Metrological and technical requirements for weight classifiers are included in NIST Handbook-44 because they have significant advantages for use in commerce. As far as we are aware, only the U.S. and Canada recognize this important technology. In this presentation, we are describing the design of the weight classifier, explaining its advantages in certain important applications and encouraging its recognition in R 76.

The rounding technique most familiar in measuring instruments consists of rounding-off the result to the nearest discrete indication. It is usually the preferred method because it limits the maximum size of the resulting error to one-half the interval. Similarly, in arithmetic rounding, a decimal fraction is rounded to the nearest whole value. This is the technique assumed throughout R 76. In fact, there is no provision in R 76 for any other type of rounding, in spite of possible benefits from alternative methods.

The weight classifier is a weighing instrument that indicates the highest weight in the scale interval within which an unknown falls. It does this by rounding up, so that the indicated weight is the highest value within the interval. It is similar to arithmetic rounding, where a decimal fraction is rounded up to the next higher whole value. The virtue of this method is linked to the nature of the application of the instrument. In suitable applications, the weight classifier eliminates all undesirable effects of rounding. However, care must be taken, because when used in the wrong application, it will cause rounding errors up to the size of the entire interval and introduce an average rounding error of one-half interval.

Rounding error of digital indication is defined in R 76, T.5.4.3 as the "Difference between the indication and the result the instrument would give with analog indication". While this definition refers specifically to digital indications, rounding error is found in many types of non-electronic instruments as well, since it is the inevitable result of the transformation from a continuous ("analog") value to a numeric quantity with a finite resolution.

Dial scales have an index whose position represents an analog value based on weight, and scale marks to allow a numeric representation of the load to be obtained. In principle, those scales offer the user the capability of estimating a result on a continuous basis. But in practice, the users will commonly interpret the result in one of two ways. They will either round-off the index position to the nearest scale mark, or round-up to the next higher scale mark, depending on the application. The typical method of use will result in a rounding error, in spite of the scale allowing for observation of a continuous output. Since as a practical matter, rounding is taking place regardless of scale type, an important distinction with digital scales is that the operator of a the dial scale can choose the type of rounding which is most appropriate for his application. On the digital scale, no such choice is available.

* Presented at the OIML Seminar "Weighing in Braunschweig" 15-18 May 1990.

For the dial scale in a retail application, the analog position of the index is equated to the value of the nearest mark. This is a round-off process performed by the clerk which is identical in principle to the process automatically performed in an electronic digital scale. For the dial scale in a tariff application, such as shipping parcels, the load value is instinctively determined by the operator on the basis of whether the index is "not over" the nearest scale mark. This is a round-up process in which the load is classified as being within one weighing range versus another. This allows the load to be aligned with a weight entry on a tariff schedule, whose weight entries typically have the heading "NOT OVER (kg)".

The notched beam scale on the other hand is a mechanical device whose output can only be read in discrete intervals. An example is a scale with a balance beam on which a weight (poise) can be placed into notches, with a resolution of one kg. When a random unknown is on the platter, the poise is moved until the unknown is determined as being within a particular range of weight. For example, an unknown of 49.3 kg will be determined to be within 49 to 50 kg, by observing changed beam position associated with these successive poise positions. This measurement can be characterized as a weight classification. Since the load can be of any value within a one kg interval, the magnitude of the rounding error can be up to one kg.

These properties of the notched beam are a handicap in retail applications, but are ideal in tariff applications. With the perfect coordination of the over/under readings against the entries in the tariff schedule, the economic impact of rounding errors is eliminated. Further, the scale interval size is immaterial, as long as it is not larger than the tariff schedule's weight interval between price changes.

The digital scale can be configured with any rounding technique desired. With equal ease, it can be designed to:

- round-off (for "weigher" functions)
- round-up (for "classifier" functions)
- round-down (for minimum net weight verification).

The choice of round-off is best for the broadest category of applications.

Certainly, if commodities are being weighed for sale, it is important that the rounding errors be minimized. Further, it is a major advantage for the indicated value to be centered within its associated range of loads, so that with a stream of typical random weighings, the economic effects of the rounding errors would average to zero. The seller thus has no lingering advantage, and the buyer, in a less obvious fashion, will likewise suffer no disadvantage over the course of many purchases.

An alert consumer might occasionally complain about a bias in the seller's favor when non-random weighings are being performed. For instance, if beluga caviar were trickled onto the platter until the indicator changed, the actual load would be 1/2 division less than indicated. Living in an imperfect world, we would accept such situations as "rare events", and be satisfied with results of the typical weighing application.

But should we be satisfied if digital scales were limited to this rounding technique? While weighing and pricing of commodities is a most common scale application, there are other important applications which yield dramatically different results, which are much better served by the use of weight classifiers. All transactions based on the use of a tariff schedule (or "rate chart") which have weight entries in the form of a sequence of ranges fall into this category. These are easily recognized by the words "NOT OVER" in the heading of the weight column. Similarly, "WEIGHT NOT TO EXCEED", "WEIGHT UP TO", and "WEIGHT BETWEEN" all have the same result. (Of course in the last case, the weight column entries each consist of two values). Such tariff schedules are the basis of shipping charges, overweight penalties, postage, and many tax schedules (as for example, vehicle registration fees). Every parcel handled by either the Post Office or a private carrier is priced in this manner.

The results can be summarized:

ROUNDING METHOD	APPLICATION	RESULT
Weigher (Round-off)	Retail sale	Max. rounding error is 1/2 d. Average economic impact is zero. (No room for improvement).
Weigher (Round-off)	Tariff schedule	Max. rounding error is 1/2 d. Average economic impact is 1/2 d in favor of the customer.
Classifier (Round-up)	Tariff schedule	No rounding error; perfect coordination of scale with tariff schedule.
Classifier (Round-up)	Retail	Max. rounding error is one d. Average economic impact is 1/2 d in favor of seller. (Inappropriate application).

Implications for R 76

At this time, R 76 provides no definition, requirements, or testing methodology for weight classifiers, and many OIML countries will not approve their use. Reservations are understandable. If these instruments are allowed without careful consideration, the regulatory system would have an added burden, and there might be instances of inappropriate application.

Proper implementation would include the following:

1) Marking requirements

- All such devices should be labelled as "WEIGHT CLASSIFIERS" and as special purpose devices, such as "FOR POSTAL USE ONLY". The official will then be aware that accuracy tests must be conducted differently, and be in a position to prevent inappropriate application of this principle.

2) Inspector training

- Inspectors face an extraordinary variety of equipment for which they are responsible. The addition of a scale that requires different test procedures makes their job more complex. Training material with examples in R 76 will have to be provided.

Accuracy testing of weight classifiers

1. Laboratory test procedure — Determining actual error

Add error weights until the indication has incremented.

$$\text{ERROR} = I - (L + \Delta L),$$

where • I is initial indicated weight

• L is the initial test load

• ΔL is the added error weight at which the indication changes

(Note that the algebraic result has the correct sign).

2. Field test procedure No. 1 — Pass/Fail Determination

- Place a weight equal to the tolerance on the scale and rezero.
- Place a test load on the scale and observe the indicated weight. If the indicated weight:

- a. is equal to or less than the test load, add a weight equal to the tolerance. Now, the indicated weight must exceed the test load.
 - b. exceeds the test load, remove a weight equal to the tolerance. Now, the indicated weight must not exceed the test load.
3. Field test procedure No. 2 — Determining maximum error without use of error weights

Place test load on scale and see chart.

INDICATED WEIGHT	MAXIMUM ERROR
$I = L$	$- d$
$I = L + nd$	$+ nd$
$I = L - nd$	$-(n + 1) d$

Where $n = 1, 2, 3 \dots$

Electronic scales as classifiers

The discussion thus far has ignored the effects of performance errors by assuming the illustrative scale was errorless. Also ignored were any characteristics of modern electronic scales that might be of particular interest with regard to use as classifiers.

Electronic scales of Class III accuracy are used in high volume in retail applications, where the use of load cell technology allows for 3 000 divisions at competitive prices. These scales are all weighers rather than classifiers.

Likewise, there are large numbers of shipping scales of similar design, used in both private shipping rooms and at post office windows. With occasional exceptions, the former are not regulated, and so the typical regulatory restrictions regarding classifiers are not relevant. Classifiers are often used in these shipping rooms because of the conviction of companies such as ours that these are better suited to shipping applications where service charges are based on tariff schedules.

How important is the rounding error that the weigher imposes? It's importance depends on (a) a comparison with the size of the performance error, and (b) the relative error that results. With its contribution of a fixed bias of $1/2 d$ in tariff applications, it equals the maximum initial verification error at 500 d, and is of course one-half of it at 2 000 d. Since the performance error under most conditions will be considerably smaller than the maximum allowed, the fixed $1/2 d$ rounding effects are critical in comparison.

The fixed $1/2 d$ rounding effect also serves to contribute a large relative error at lower applied loads; specifically it increases from 0.1 % at 500 d, to 2.5 % at 20 d. A weighing instrument with zero rounding error which has a performance error which is small at light loads (well below $1/2 d$ at loads much smaller than 500 d) offers an ideal answer to the relative error issue.

Fortunately, electronic scales such as those with load cells typically have performance errors which shrink rapidly as loads decrease, as the following exercise indicates.

The total performance error is the result of the contributions of a variety of error types. These fall into two major categories-independent of load, and proportional with respect to load.

INDEPENDENT

PROPORTIONAL

Electronic noise

Internal count resolution

Span change with temperature

Span drift with age

Tilt

Shift

Non-linearity (at light loads)

Calibration error

Hysteresis (ignore for "Random Weighings")

All of the terms on the right virtually disappear at very light loads. The relative error for a suitably applied classifier will be small if noise is small and internal count resolution is adequate.

In a typical scale with Automatic Zero Tracking (AZT), under microcomputer control, a "zero register" stores the count value associated with the empty platter, and its value is continually adjusted for small changes; subtraction of this value from a higher gross count yield a stream of net counts, which are the basis for displayed weight values.

This scale cannot distinguish zero except to the nearest count, and the effect of noise can be viewed as the result of the changes in the analog signal during the time between the most recent zero register update and the next determination of gross count. This yields the following relationship:

NOISE (IN EQUIVALENT COUNTS PEAK-TO-PEAK)	MAXIMUM OUTPUT VARIATION
< 1	± 1
1-2	± 2
2-3	± 3

In a 3 000 d scale with a load cell, the internal count resolution might reasonably be chosen at 30 000 (10 times the displayed resolution). To derive maximum benefit from this internal resolution, we see from the table that the noise should be held to within one count. The key relationships to achieve this in a typical scale design are as follows:

- a) Output of load cell
 $2 \text{ mV/volt} \times 10 \text{ volts (excitation)} = 20 \text{ mV}$,
 and live load range = $3/4 \times 20 \text{ mV} = 15 \text{ mV}$
- b) With 30 000 internal counts (live load range), one count is equivalent to
 $15 \text{ mV}/30\,000 = 0.5 \text{ microvolt}$.

This is readily obtainable at moderate cost with modern designs. Low-pass filtering is necessary which takes advantage of the modest response times expected from a non-automatic scale. This is done either by use of analog filters, or by arithmetic averaging of a succession of digital conversion outputs.

Relative errors are thus held small over considerably more of the weighing range than intuition might suggest. This capability makes possible the successful design of multi-interval scales. With these, rounding errors are reduced in lower partial ranges by the use of smaller scale intervals. Even here, further improvement is possible with the use of classifiers. It affords the only means to achieve the elimination of all rounding errors throughout the scale's weighing capacity.

Summary

The digital scale can be easily configured to allow best performance in any application. A weigher can be redesigned to function as a classifier by simply subtracting one-half "d" from the analog result at which the indication changes. In micro-computer-controlled scales, a modest software change is all that is required. The outstanding performance of digital scales with their small relative error over a broad weighing range offers a unique opportunity in tariff applications. Used as a classifier with elimination of rounding error effects, the maximum equity would be obtained. The improved results would apply to any service charge, fee, or tax based on a weight range.

In many countries, regulatory interpretations prevent the advantageous use of the classifier. Inclusion in R 76 would remove this barrier.

FINLANDE

GRAVITY COMPENSATION of WEIGHING INSTRUMENTS in FINLAND

by T. LAMMI

Technical Inspection Centre, TTK, Weights and Measures Office, Helsinki

SUMMARY — This paper concerns gravity sensitive weighing instruments which are verified at a location other than that where they are used. The special verification procedures which can be applied to these instruments in Finland as well as the accuracy of the procedures are dealt with.

1. Introduction

If a gravity sensitive weighing instrument is verified at a location which is different from that where the instrument is used then the different values of the acceleration due to gravity, the g -values, of the two locations are a source of error. To avoid the error the effect of the g -values is usually compensated or the verification is carried out in some special districts. Each district should then be defined so that the errors due to the g -values are restricted to some limits fixed in advance. How wide the districts can be, what are the fixed error limits and in what cases the instrument cannot be verified outside its location of use are the topics of this paper.

The problem of the g -values is the same in all countries where instruments are verified, although the practical solutions employed may be different. We restrict ourselves to a solution compiled for Finland and try to explain the underlying considerations which, we hope, may make a contribution to an advanced treatment of the problem.

2. Verification conditions

2.1. The verification of a weighing instrument can be carried out at a location distinct from that where it is used in the two following cases:

2.1.1 Without taking into account the values of g on condition that:

- the number n of verification scale intervals is $n \leq 3\,000$ and
- the difference $\Delta\Phi$ of the latitudes of the two places (the place of verification and use) is $|\Delta\Phi| \leq 1^\circ$ and
- the difference Δh_i of the altitude between the two places does not exceed 200 m.

The descriptive markings of the instrument shall bear information of the location or the district where the instrument can be used.

2.1.2 When $n \leq 3\,000$ and $|\Delta\Phi| > 1^\circ$ and/or $|\Delta h_i| > 200$ m if the effects of the variations of g are compensated as explained in Section 4.

The descriptive markings of the instrument shall bear information of the location where the instrument can be used.

2.2. The verification cannot be carried out at a place distinct from that where the instrument is used if

$n > 3\,000$; the instrument should then be verified in-situ only.

The descriptive markings of the instrument shall bear information of the place, e.g., the building and its story where the verification is carried out.

3. The effect of variations in g

Let us investigate the effect Δm of the g -values (in unit of measurement of mass) on an instrument at two different locations, place A where the instrument is verified and place B where it will be used. The effect is obtained from the well known formula

$$\Delta m = L(g_B - g_A)/g_A \quad (1)$$

where L is the load by means of which the span of the instrument is adjusted, g_B is the value of g at B and g_A at A.

In what follows we assume that L equals the maximum capacity Max of the instrument, i.e., $\text{Max} = L = ne$ (n = number of verification scale intervals e).

The value g_A is assumed to be known, but usually the value g_B is not known accurately enough. This is due to the possible anomaly (Bouguer anomaly) in the g -value at B, the geographical altitude and the height of the story in the building where the instrument will be used at B. These and the geographical latitude are the factors influencing of g (cf. Appendix B.1.1).

In order to take the factors of g into consideration and to obtain a realistic understanding of the effect Δm we express it as a multiple (or a submultiple) of the verification scale interval e of the instrument, i.e.,

$$\Delta m = re \quad (2)$$

r is a coefficient defined below.

4. The coefficient r and the application of Δm

4.1. The value of r and determination of Δm in Finland

The value of r in (2) is obtained using the following formula (cf. Appendix B.1):

$$r = n(0.000\,7\,\Delta\Phi - 0.000\,002\,\Delta h_1 - 0.000\,003\,\Delta h_2 + \Delta a)/g_A \quad (3)$$

where

- n is the number of scale intervals e .
- $\Delta\Phi$ is the difference between the latitudes Φ_B and Φ_A of B and A respectively ($\Delta\Phi = \Phi_B - \Phi_A$). Its unit of measurement is $[\Delta\Phi] = 1^\circ$.
- Δh_1 is the difference in metres of the geographical altitudes $h_{1,B}$ and $h_{1,A}$ of B and A respectively. These values are obtained from the topographical maps.
- Δh_2 is the difference of the heights $h_{2,B}$ and $h_{2,A}$ of the stories of the buildings where the instrument is used at B and where it is verified at A respectively.
- Δa is the difference in m/s^2 of the (Bouguer) anomalies a_B and a_A of g at B and A respectively, ($\Delta a = a_B - a_A$). The values a_B and a_A are obtained from the maps of anomalies (see Fig. 1).

The formula (3) does not apply where A or B is below ground level.

EXAMPLE

Let the value g_A be 9.8198 m/s^2 at A where the verification is carried out. The instrument is to be used at B which is situated north of A so that $\Delta\Phi = +1^\circ$. The differences Δh_1 and Δh_2 are both 0 m. The anomaly at B is

$a_B = +0.0002 \text{ m/s}^2$ and at A it is $a_A = -0.0001 \text{ m/s}^2$. Thus

$$\begin{aligned}\Delta\Phi &= +1^\circ \\ \Delta h_1 &= 0 \text{ m} \\ \Delta h_2 &= 0 \text{ m} \\ \Delta a &= +0.0003 \text{ m/s}^2\end{aligned}$$

r is obtained from (3). It is:

$$r = n(0.000102)$$

Then if

$n = 1\ 000$	$r = 0.102$
$n = 2\ 000$	$r = 0.204$
$n = 3\ 000$	$r = 0.306$
$n = 4\ 000$	$r = 0.408$

Using the equation (2) we obtain the effect Δm .

Note that Δm is now calculated using g_A together with the values of the factors of g which hold at B and which can be obtained from maps. Thus the actual value of g_B is not needed. Further, we do not need to know the value of g_A exactly. If it is given so that its error is 0.01 m/s^2 then the contribution of the error to the total relative error of Δm is about $1/1000$.

4.2. The application of Δm

The application of Δm when the instrument is verified or the span of the instrument is adjusted is as follows: if $\Delta m > 0$ add a load corresponding to Δm to Max load ($\text{Max} = L$). Then if the indication of the instrument is Max the instrument is verified at A and can be used at B. Otherwise adjust the instrument to indicate Max. If $\Delta m < 0$ subtract a load Δm analogously and follow the previous procedure.

5. Maximum permissible effect Δm

After verification, the instrument should comply with the metrological requirements of OIML-Recommendation R 76-1 and they should be met independent of the place where the instrument is verified or used.

From the practical point of view some error resulting from the effect Δm should be permitted. In what follows we permit an error which is not greater than $0.3 e$. This is because $0.3 e$ can be regarded as a practical "accuracy" of the span adjustment of the instrument.

On the basis of (2) the error caused by Δm is less than $0.3 e$ if the following condition

$$|r| \leq 0.3 \quad (4)$$

is met and vice versa.

6. Selection of verification procedures

Procedure 2.1.1

Suppose that the conditions of 2.1.1 are to be met. Then if one goes through the actual locations A and B in Finland where instruments are verified and used and calculates values for the coefficient r so (4) should be met without exception if $n = 2\ 000$ and met approximately if $n = 3\ 000$. In the case $n = 3\ 000$ the problem is how frequently and by how much the limit 0.3 in (4) may be exceeded or, in other words, how frequently and by how much the errors resulting from the effect Δm may exceed $0.3 e$.

In Appendix A (A.1.2) we will give an example where the conditions of 2.1.1 are met. The results in the example show that if $n = 2\,000$ then r is -0.3 and if $n = 3\,000$ then r is -0.45 . In this case procedure 2.1.1 should lead to "acceptance" of (4) if $n = 2\,000$ but to "rejection" if $n = 3\,000$. So in the case $n = 3\,000$ this procedure leads to an error $-0.45e$ which is greater than the permissible error $\pm 0.3e$. Very seldom, however, the errors may be greater than $0.3e$. Even then they do not exceed $0.5e$ in practice. The probability that the errors exceed $0.3e$ can be approximated to be less than 0.25. This will be dealt with in Appendix A.

Procedure 2.1.2

An increase in the value of the latitude usually increases the value of r . This can be seen from (3) and from Table 1 in Appendix A (A.1.1). Sometimes, however, the anomaly effect or the effect of the height h_1 or h_2 may compensate the effect of the increase of the latitude, and two locations with the different latitudes ($|\Delta\Phi| > 1^\circ$) may even have the same g -values and $r = 0$. But in this case procedure 2.1.2 should be applied and by means of (3) one should show that $r = 0$.

In general, procedure 2.1.2 should be applied in order to avoid excessive errors ($> 0.3e$) due to gravity. The existence of these errors when $|\Delta\Phi| > 1^\circ$ and/or $|\Delta h_1| > 200$ m can be regarded as obvious (cf. Table 1 in Appendix A). The compensation of the effect Δm is performed using r from (3) and then calculating Δm according to (2) and applying 4.2. The error brought about by this procedure depends on the accuracy of determining Δm . This on the other hand can be determined to within $\pm 0.3e$ as long as $n \leq 3\,000$.

Procedure 2.2

As we can see from (3) and from the example in 4.1 as well as from the example A.1.2 in Appendix A the absolute value of the coefficient r will increase as n , the number of scale intervals, increases. If n for an instrument could take on different values then e should decrease as n increases. Thus when n is "large" ($n > 3\,000$) the value of the scale interval e and the error $0.3e$ can be regarded as being relatively "small". Now if the verification were carried out outside the place of use of the instrument then $\Delta m = re$ should be determined "very" accurately in order to be able to obtain a precise compensation of Δm . Note that we have to be sure that the errors after compensation are not greater than the "small" error $0.3e$. On the basis of our experience we have noticed that one may sometimes succeed in achieving accurate compensation but sometimes not. This is because even a small error in Δm may be significant. This is due to the fact that very often, especially when $|\Delta\Phi| > 1^\circ$ the ratio, $e/\Delta m$ is relatively small. So after compensation there may exist errors caused by Δm which are greater than $0.3e$ and even greater than $0.5e$. So verification of instruments for which $n > 3\,000$ cannot reasonably be carried out outside the place of use. Thus verification in-situ is perhaps the only practical solution. There is then no problem with the error due to gravity.

APPENDIX A

A.1 Upper limit of r

A.1.1 A mathematical approach

Let us investigate the upper limit of r for the equation (3) when the absolute values of Δh_1 , Δh_2 and Δa are:

$$\begin{aligned} |\Delta h_1| &= 200 \text{ m} \\ |\Delta h_2| &= 0 \text{ m} \\ |\Delta a| &= 0.000\,3 \text{ m/s}^2 \end{aligned}$$

Taking into account these values we can write for the absolute value of r

$$|r| \leq n (0.000\,7 |\Delta\Phi| + 0.000\,002 |\Delta h_1| + |\Delta a|) / g_A = 0.000\,7 n (|\Delta\Phi| + 1) / g_A \quad (5)$$

In the following Table 1 we give the values of $|r|$ according to (5) when $|\Delta\Phi|$ takes on the values 0.5° , 1° , 1.5° , and 2° and $n = 1\,000$, $2\,000$ and $3\,000$.

Table 1. Upper limit of $|r|$ according to (5) for $n = 1\ 000-3\ 000$ and $\Delta\Phi = 0.5^\circ-2^\circ$

n	$ \Delta\Phi $			
	0.5°	1°	1.5°	2°
1 000	$ r = 0.107$	$ r = 0.142$	$ r = 0.178$	$ r = 0.214$
2 000	0.214	0.284	0.356	0.428
3 000	0.321	0.426	0.534	0.642

From this Table we see that the upper limit of $|r|$ is 0.426 for $|\Delta\Phi| = 1^\circ$ and $n = 3\ 000$ and thus for the case in which the conditions of 2.1.1 are met. However, 0.426 is a fairly pessimistic limit corresponding to the case in which the factors $\Delta\Phi$, Δh_1 and Δa in (3) reinforce one another. This is a fairly rare event (cf. A.1.3). In any case in Table 1 the absolute value of r is at most 0.5 when $n \leq 3\ 000$ and $|\Delta\Phi| \leq 1^\circ$.

A.1.2 An extreme example

Let the value of g_A be $g_A = 9.825\ 4\ \text{m/s}^2$ at a place A (Inari, Lapland) where the verification is carried out. The instrument is to be used at a place B situated south of A so that $\Delta\Phi = 1^\circ$, $\Delta h_1 = 120\ \text{m}$, $\Delta h_2 = 10\ \text{m}$ and $\Delta a = -0.000\ 5\ \text{m/s}^2$. Substituting these in (3) we obtain

$$r = n(-0.000\ 7 - 0.000\ 77)/9.825\ 4 = n(-0.000\ 150)$$

Then if

$$\begin{array}{ll} n = 1\ 000 & r = -0.15 \\ n = 2\ 000 & r = -0.30 \\ n = 3\ 000 & r = -0.45 \end{array}$$

In this example, which is deliberately selected, all the terms in the parenthesis of (3) reinforce one another. In any case the absolute value of r is at most 0.5 when $n \leq 3\ 000$.

A.1.3 "Local" upper limits of $|r|$

Let us suppose that Finland is divided into "districts" the latitudes of which are: $60.5^\circ \pm 1^\circ$, $61.5^\circ \pm 1^\circ$, ..., $69.5^\circ \pm 1^\circ$. From each district we choose the greatest absolute value of Δh_1 and Δa (Δh_2 is assumed to be zero). According to (3) we calculate values of $|r|$ corresponding to $n = 1\ 000$ and to all the different combinations of $\Delta\Phi = \pm 1$, $\pm|\Delta h_1|$ and $\pm|\Delta a|$ where the values of Δh_1 and Δa are the above mentioned greatest values. The number of combinations is 8. Two of the combinations can lead to extreme cases, viz. the combinations $\Delta\Phi = +1$, $+\Delta h_1$ and $+\Delta a$ and $\Delta\Phi = -1$, $-\Delta h_1$ and $-\Delta a$. Thus the probability of such extreme events is $2/8 = 0.25$.

We obtain the values given in Table 2a. In Table 2b we also give the results of 8 combinations of the same values as above but $|\Delta a| = 50 \times 10^{-5}\ \text{m/s}^2$. This value is a typical value representing the greatest difference of anomaly effect in Finland (see Fig. 1).

The most pessimistic values of $|r|$ corresponding to $n = 1\ 000$ for the "districts" $\Phi = 60.5^\circ \pm 1^\circ, \dots, 69.5^\circ \pm 1^\circ$. The values are obtained as the results of 8 combinations of $\Delta\Phi = \pm 1$, $\pm|\Delta h_1|$ and $\pm|\Delta a|$. The last column gives the number of cases in which $|r| > 0.1$ and ≤ 0.1 . $|r|$ for $n = 3\ 000$ can be obtained by multiplying the given values of $|r|$ by 3.

We see from the last column in Tables 2a and 2b that at least 50 % (4/8 or 6/8) of the cases should lead to values $|r| \leq 0.1$ if $n = 1\ 000$ and to $|r| \leq 0.3$ if $n = 3\ 000$. This is not met for districts $68.5^\circ \pm 1^\circ$ and $69.5^\circ \pm 1^\circ$.

Table 2a

Latitude Φ (°)	Greatest $ \Delta h_1 $ (m)	Greatest $ \Delta a \times 10^{-5}$ (m/s ²)	Range of $ r $ corresponding to $n = 1\ 000$
60.5 ± 1	162	85	0.12-0.19 in 4 cases 0.02-0.05 in 4 "
61.5 ± 1	223	95	0.12-0.21 in 4 " 0.02-0.07 in 4 "
62.5 ± 1	269	90	0.11-0.21 in 4 " 0.03-0.08 in 4 "
63.5 ± 1	361	80	0.23 in 2 " 0.06-0.80 in 6 "
64.5 ± 1	388	70	0.22 in 2 " 0.06-0.08 in 6 "
65.5 ± 1	432	75	0.24 in 2 " 0.06-0.1 in 6 "
66.5 ± 1	462	40	0.12-0.21 in 4 " 0.02-0.06 in 4 "
67.5 ± 1	568	85	0.13-0.27 in 4 " 0.04-0.10 in 4 "
68.5 ± 1	862	95	0.15-0.34 in 6 " 0.01 in 2 "
69.5 ± 1	1 238	95	0.23-0.43 in 6 " 0.08 in 2 "

Table 2b

60.5 ± 1	162	50	0.16 in 2 cases 0.01-0.08 in 6 "
61.5 ± 1	223	"	0.17 in 2 " 0.03-0.08 in 6 "
62.5 ± 1	269	"	0.18 in 2 " 0.03-0.08 in 6 "
63.5 ± 1	361	"	0.20 in 2 " 0.05-0.09 in 6 "
64.5 ± 1	388	"	0.20 in 2 " 0.04-0.10 in 6 "
65.5 ± 1	432	"	0.11-0.21 in 4 " 0.03-0.07 in 4 "
66.5 ± 1	462	"	0.11-0.22 in 4 " 0.03-0.07 in 4 "
67.5 ± 1	568	"	0.14-0.24 in 4 " 0.01-0.10 in 4 "
68.5 ± 1	862	"	0.16-0.30 in 6 " 0.05 in 2 "
69.5 ± 1	1 238	"	0.13-0.37 in 8 "

It must be kept in mind that the results in Tables 2a and 2b are obtained from combinations of extreme values. The real cases would result in smaller values of $|r|$. In addition if the condition $|\Delta h_1| \leq 200$ of procedure 2.1.1 were taken into account the values of $|r|$ would be even smaller. Then the greatest value of $|r|$ is 0.483 if $|\Delta a| = 50 \times 10^{-5} \text{ m/s}^2$ and $n = 3\,000$ and 0.626 if $|\Delta a| = 95 \times 10^{-5} \text{ m/s}^2$ and $n = 3\,000$. In 6 we mentioned that in the case where the conditions of 2.1.1 are met $|r|$ cannot exceed 0.5 in practice or the error brought about by Δm cannot exceed $0.5 e$. Now we see that this statement is quite well motivated.

APPENDIX B

B.1 Derivation of the coefficient r in (3) in Section 4

B.1.1 Factors of g

The acceleration due to gravity g can be written in the following form:

$$g = g_{\Phi} + g_{h_1} + g_{h_2} + a \quad (6)$$

where

- g_{Φ} is the factor of g due to the latitude Φ (cf. (7) in B.2),
- g_{h_1} is the factor of g due to the geographical altitude h_1 (in Finland $g_{h_1} \approx -2 \times 10^{-6} h_1$),
- g_{h_2} is the factor of g due to the height h_2 of the story of the building where the value of g is determined (in Finland $g_{h_2} \approx -3 \times 10^{-6} h_2$),
- a is the (Bouguer) anomaly obtainable from maps of anomalies (see Fig. 1).

B.1.2 Equation (3) in Section 4

Applying (6) for the places A and B we obtain g_A and g_B . Inserting these in (1), using g_{Φ} given in (7) in B.2 and taking into consideration that $\Delta m = re$ and $L = \text{Max} = ne$ we obtain (3).

B.2 Values of g_{Φ}

In the following Table 3 we give some values of g_{Φ} in Finland.

Table 3. Values of the factor g_{Φ}

Φ (°)	g_{Φ} (m/s ²)
60	9.819 10
61	9.819 87
62	9.820 63
63	9.821 37
64	9.822 10
65	9.822 80
66	9.823 48
67	9.824 15
68	9.824 79
69	9.825 40
70	9.826 00

These values can be approximated from the following simplified formula:

$$g_{\Phi} = 0.000 7 \Phi + 9.777 2 \text{ (m/s}^2\text{)} \quad (7)$$

where the unit of measurement of Φ is (°). The errors in the values obtained from (7) are at most $0.000 2 \text{ m/s}^2$.

Acknowledgement

I am indebted to Mr. A. Pusa, Raute Precision Lahti, for constructive discussions concerning the matter and for help in compiling Tables 2a and 2b.

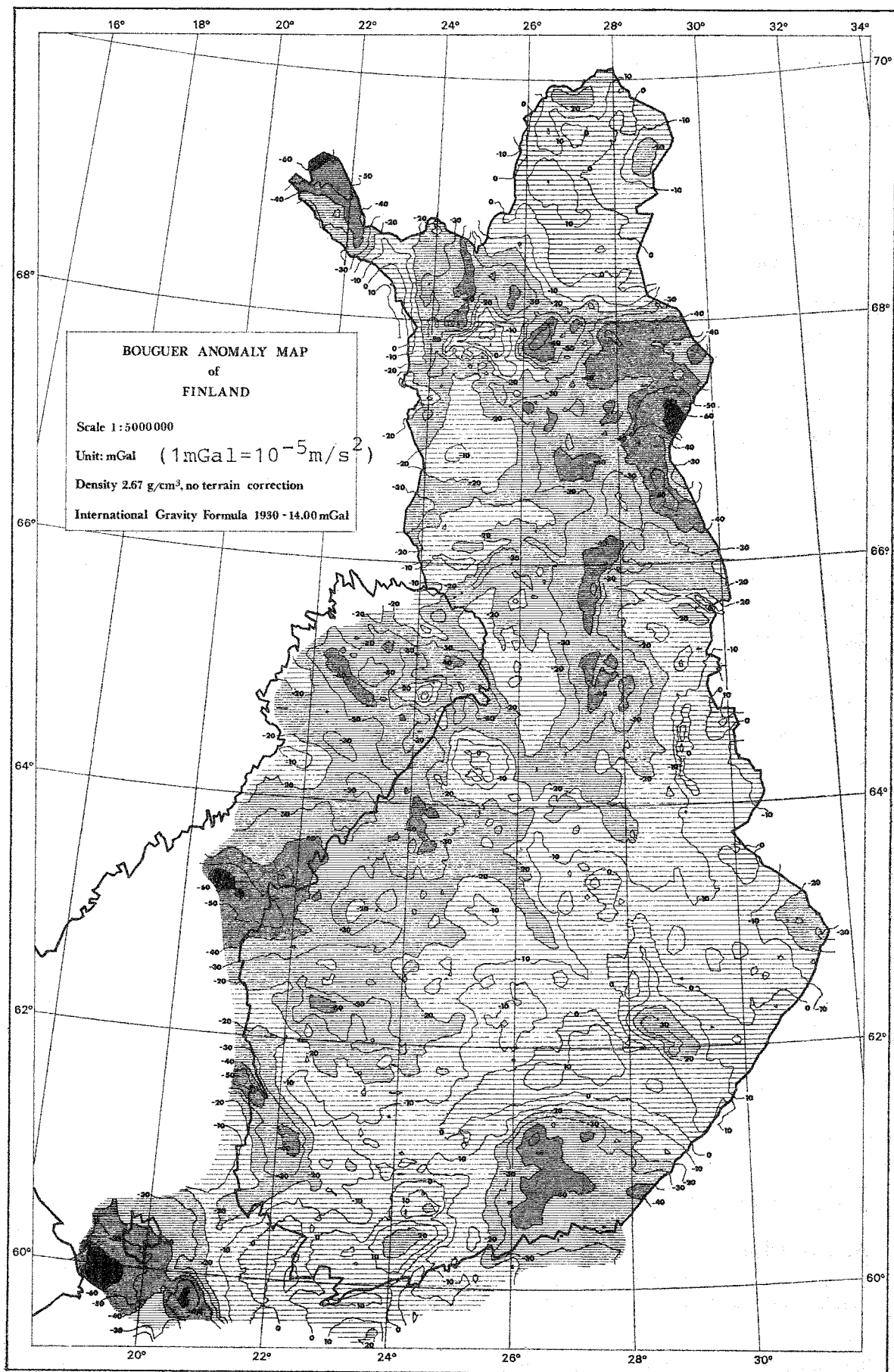

Maanmittaushallituksen karttapaino, Helsinki 1982

Fig. 1

ROYAUME-UNI

The IMPACT of the " GRAVITY EFFECT "
on WEIGHING MACHINES
and METROLOGICAL LEGISLATION

by **D.H. FEREDAY**

Managing Director, H. Fereday and Sons Ltd.

SUMMARY — This paper presented at the OIML seminar Weighing in Braunschweig, 15-18 May 1990 exposes an instrument manufacturer's point of view on the application of gravity zones to weighing instruments based on force measurements such as strain gauge load cells. The paper includes the result of a survey made by its author on the application of regulations in various countries relative to instruments the indications of which are affected by the acceleration due to gravity.

Introduction

That benevolent force which converts itself through the many various types of weighing mechanisms to swing round an indicator or activate the digits must remain constant for consistent accuracy of most modern weighing instruments be they located up Everest, on the Dead Sea, at equator or pole.

Unfortunately gravity is not quite so friendly and its variation is a technical irritant. Legal metrology in many countries recognizes this phenomenon, but regulations are distinctly different from one individual state to another. This varies from disallowing any machines sensitive to gravity for trade applications in one particular country to other countries such as the U.K. that make no provision in their regulations for potential gravity induced errors.

From the 82 OIML member and corresponding member countries, 22 have a significant variation of latitude. I have made research into how those countries' weights and measures authorities regulate for weighing errors caused by weighing equipment being moved between the extremes of their latitude. I will be elaborating on this later in the paper.

I will be purposefully only considering Class III machines as such equipment forms the majority of weighing scales in use for trade and I will be examining the effect on the consumer of the consequence of goods being sold over scales calibrated distant from their point of use.

The extent of gravity variation

Gravity from equator to pole increases at mean sea level by 0.53 % — that is approximately one part in two hundred. This is basically caused by the spinning globe

which produces centrifugal forces which are at a maximum at the equator and zero at the poles. These forces act against the gravitational force and therefore gravity is reduced as one moves from pole to equator.

A further factor is that the world has a larger diameter at the equator than the pole. This difference at mean sea level is 33 km. As gravitational pull reduces as distance from the earth's centre is increased, gravity is therefore further reduced from pole to equator to give the total difference of 0.53 %.

Of lesser effect is altitude variation. Gravity varies by 0.03 % for every 1 000 metre change in height. For gravity sensitive scales to vary by just one division in a thousand their location must be changed by 3 300 metres in height.

The acceleration due to gravity at any particular latitude may be computed from the formula:

$$g = G (1 + b_1 \sin^2 \Phi - b_2 \sin^2 2\Phi) - 3.086 \times 10^{-6} H \quad \text{m/s}^2$$

where Φ = latitude, H = height in metres above sea level,

G = gravity at equator = 9.780 318 4 m/s²,

b_1 = 0.005 302 4, b_2 = 0.000 005 9.

This produces a spectrum of gravity variation as shown in the graphs Fig. 1a and 1b.

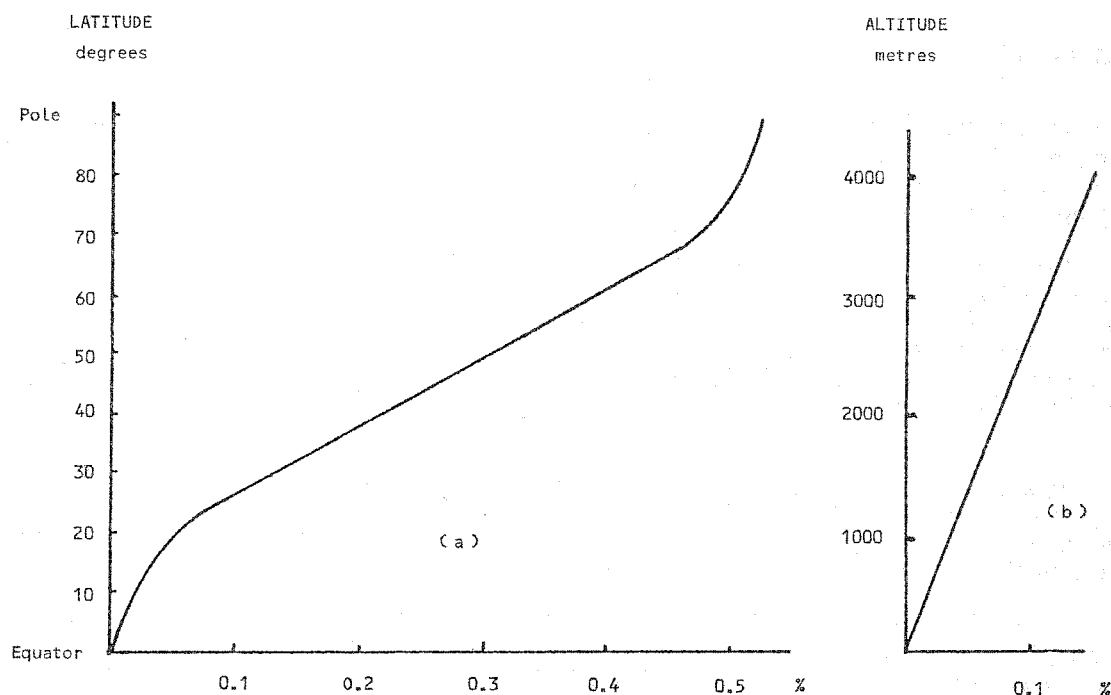

Fig. 1 (a) — Increase in "g" at constant altitude
(b) — Decrease in "g" at constant latitude

A broad rule of thumb is that a weighing machine whose accuracy is sensitive to gravity will vary by one part in a million for every mile (1.6 km) change in latitude.

In passing it should be mentioned that air buoyancy, rock formation, and the type of terrain will affect the weight of a mass. These factors may give rise to a local gravity variation of up to 1 part in 10 000 which is of no consideration for class III weighing instruments.

Types of instruments that are gravity insensitive

It is probably well known that there are types of weighing machines that by virtue of their operating principle remain unaffected by change of location — for example instruments whose resistance is controlled by a counter weight which includes the many traditional types of steelyard and pendulum mechanisms, electronic instruments controlled by twin vibrating wires and other systems that automatically compensate for gravity.

The modern high-technology gravity compensated principles are generally expensive, and are more usually employed in specialist equipment rather than trade weighing.

Gravity sensitive instruments

The majority of Class III machines especially in the developed world, are affected by gravity, and I am referring to spring and load cell/transducer controlled scales.

When spring actuated instruments were introduced, although sensitive to gravity, their relatively low resolution made any "gravity error" seem insignificant in relation to scale interval size. It was only with the advent of load cells where a high resolution can be economically achieved that gravity variation caused noticeable reading differences if instruments were used at a latitude different from the place of initial verification.

The inquisitive mind might ponder the question as to the necessity for manufacturers to produce load cell machines with high resolution, typically 3 000 scale intervals, when they are to be used to weigh the same goods that were weighed quite satisfactorily on the lower resolution spring actuated machines of typically 500 scale intervals. Perhaps the older technology provided too coarse a division, but may be now the new technology allows too fine a weighing potential bearing in mind the relative low value of goods being weighed — for example vegetables or even meat. However, as load cell machines can easily be calibrated very accurately, manufacturers give as high a specification as possible to attract sales for their product. Regulations have had to reflect the much finer weighing made possible by modern technology, with gravity variation becoming a factor.

OIML Member country survey

My research has been confined to OIML member countries whose extremes of latitude are more than 6° which is equivalent to approximately 660 km north to south. This will induce a weighing variation of approx. 1 part in 2 000 (0.05 %). There may be countries having less gravity variation which may have a system of gravity zoning or stipulation that instruments must be verified at place of use, but potential errors would be relatively insignificant compared to R 76 tolerances which are adopted in most countries.

Out of the 22 countries with this variation of more than 6° difference in their latitude, 14 replied to the questionnaire with a variety of response (Table 1).

Table 1 — OIML member and corresponding member countries whose limits of latitude extend beyond 6° (660 km)

	Latitude Variation	Equivalent Distance (km)
* USSR	40°	4 400
Brazil	38°	4 200
* Australia	32°	3 500
* China	30°	3 300
* Canada	27°	3 000
India	26°	2 900
* USA	19°	2 100
Peru	19°	2 100
Algeria	17°	1 900
* Japan	15°	1 600
Mexico	15°	1 600
Ethiopia	14°	1 500
* Sweden	13°	1 400
* Norway	12°	1 200
* New Zealand	12°	1 200
Finland	10°	1 100
Italy	10°	1 100
* U.K.	9°	1 000
* France	9°	1 000
* West Germany	8°	900
* Spain	7°	800

* Countries responding to the survey.

The British, although acknowledging gravity, make no direct reference to the subject in regulations. This might displease Isaac Newton, an Englishman, who prompted by a bruised head whilst slumbering under an apple tree I believe was the first scientist to calculate the accelerating force gravity produces (Fig. 2).

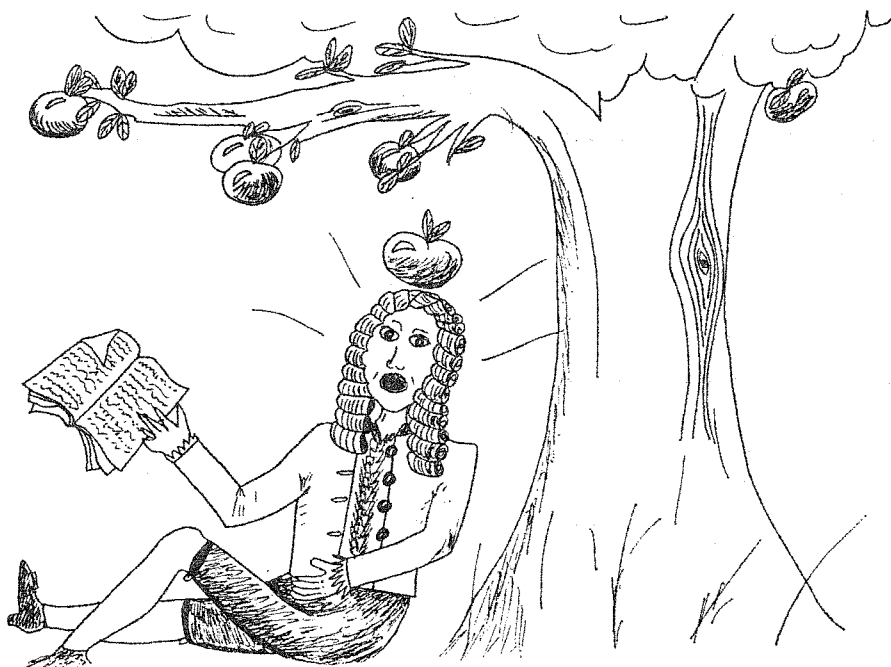

Fig. 2 Isaac Newton's discovery

Similarly Australia, New Zealand and Spain have no recognition built in their weighing machine regulations for the "gravity effect", though Australia is currently enacting regulations. Four countries treated the problem by the simple expedient of only verifying gravity sensitive machines at the place of use, whilst the other 6 operate a system of gravity zones within their boundaries. A general principle adopted by most countries with zones is that machines of lesser resolution may be used in all zones whilst those of higher resolution may only be used in the zone of verification. The

Table 2 — Summary of responses relating to recognition and regulatory control of the gravity-factor

	$V \times 10^{-3}$	Recognition in Regulations	Gravity Zones	Factory Verification Allowed	Verification only at place of use
USSR	3.3	Yes	Yes	Yes	
		No information given on number of gravity zones			
Australia	2.6	Legislation currently being enacted to ensure that instruments are verified at place of use or compensation made in testing if to be used at a place distant from verification location			
China	2.4	No	No	No	Yes
		Gravity zones are being considered			
Canada	2.2	No	No	No	Yes
U.S.A.	1.5	No	No	No	Yes
Japan	1.2	Yes	16	Yes	
Sweden	1.0	Yes	6	Yes	
		n = 1 000 or less verification valid all zones n = 1 000 — 2 500 verification valid for adjoining zones n = 2 500 — 6 000 verification valid one zone			
Norway	1.0	Yes	9	Yes	
		n = 1 500 or less verification valid all zones n = 1 500 — 3 000 verification valid for adjoining zones n = + 3 000 verification only at place of use			
New Zealand	1.0	No	No	Yes	
U.K.	0.7	No	No	Yes	
France	0.7	Yes	No	partly	
		Gravity zones are being considered			
West Germany	0.65	Yes	4	Yes	
		n = 3 000 or less verification valid all zones n = 3 000 — 5 000 verification valid for adjoining zones n = + 5 000 verification valid one zone			
Spain	0.55	No	No	Yes	
East Germany	0.3	Yes	2	Yes	

V = Relative variation in weighing result when instrument is moved between the extremes of latitudes for each country.

Table 2 details how some individual countries with gravity zones discriminate between instruments of different resolutions.

Responding countries who employ gravity zones were West Germany, East Germany, Norway, Sweden and Japan. Japan has 16 zones which could be considered as being too detailed. Sweden and West Germany in conjunction with their zonal systems allow machines to be verified at factory or distributors premises for use in a distant zone, but the calibration has to be set for the zone of use according to a pre-defined schedule.

The conclusion to be drawn from the survey is that there is a variance as to how the weights and measures authorities in different countries make or do not make regulations to respect the gravity effect, and that perhaps central guidance from OIML would be beneficial to promote a more uniform approach.

Comparison of potential gravity error to R 76 tolerances

In order to objectively assess as to whether an individual country is being, should I say it, too cavalier in their appreciation of gravity induced errors, such errors should be compared to the R 76 tolerances. Where any error induced by moving an instrument through the extremes of latitude of a country is significant compared to the R 76 verification and inspection tolerances then it would be rational to regulate accordingly.

I have arbitrarily chosen to investigate the gravity induced errors for two typical instruments used in retail shops moved through 9° of latitude which equates to 1 000 km. Instruments chosen are a 15 kg electronic model of 5 g scale interval and 15 kg capacity dial scales of 20 g scale interval. Relating the 1 000 km to OIML member countries that distance is very approximately equivalent to the extremes of latitude of the U.K., France, West Germany, Italy and Finland. Using the simple formula of one part in a million variation per mile, (1.6 km), or reading off values from the gravity graph, in Fig. 1, the following comparison with R 76 tolerances emerges (Table 3).

Table 3

Type of Instrument	Scale intervals	Load	OIML R 76 Tolerances		Weighing error induced by gravity variation over a 9° change in latitude
			Verification	In service	
Load cell instrument 15 kg × 5 g (n = 3 000)	1 000	5 kg	5 g	10 g	4 g
	2 000	10	5	10	8
	3 000	15	7.5	15	12
Dial scales 15 kg × 20 g (n = 750)	250	5 kg	10 g	20 g	4 g
	500	10	10	20	8
	750	15	20	40	12

The table clearly demonstrates that for the lower resolution, 750 scale intervals, the gravity induced error is less than verification tolerances, whilst even for the higher resolution weighing instruments, the gravity induced variations do not exceed the R 76 in service allowances.

The figures assume an instrument verified at the extreme south then used at the extreme north of the chosen band — an extremely unlikely occurrence. In reality within such a 9° spectrum of latitude the maximum likely movement of a weighing scale would be no more than 7°, that is 770 km.

It is perhaps indicated that the U.K. is being pragmatic by not recognizing gravity in their regulations. After all the maximum potential percentage of short or overweight given to the housewife would be very insignificant — a possible few grams, which compared say to the dirt on potatoes, contrived water in the chicken or excess fat in the sausage, is a small amount to get excited about.

Solutions

To assure that the public receives correct weight within a sensible tolerance, metrological legislation must recognize the phenomenon of variable gravity. As has been shown, different states have different attitudes varying from possibly being too detailed to complete lack of recognition. A function of OIML is to harmonize regulations such that eventually all member states fashion regulations to R 76. It could be further beneficial in this quest for uniformity if parameters were recommended for ensuring that member states have a similar approach and philosophy regarding gravity variation within their borders.

Solutions could be technical by regulation or a combination of both. A simple option could be to not allow gravity sensitive instruments to be used for trade, but this would preclude the vast majority of scales currently in use in developed countries. For digital readout scales the more expensive technology would have to be employed such as the gravity insensitive twin vibrating wire principle. The incorporation of a gravity sensor in a conventional load cell instrument, though technically feasible, would not be economically viable.

It would seem that control by regulation through a zonal system must be a preferred solution. The guiding parameter would be to decide what level of potential maximum weighing difference is tolerable for Class III trade use instruments. Up to one part in 1 000 could be the basis and even that level could be perceived as being too critical. Over that level there should be provision for gravity variation. Interpreting this into distance gives a figure of 1 250 km north to south to which gravity zones could be limited. Such a zone limit would combine all the gravity zones for example of West Germany and thus remove the impediment of free movement within the country. For the sake of a possible 0.1 % short or overweight on a housewives' purchase, the freedom given and lack of bureaucratic control must be, on balance, beneficial.

Such broadening of gravity zones would reduce the number in countries of deep latitude who could be split up into zones which should not exceed the 1 250 km north to south. This would for example reduce Sweden's 6 zones to 2. A worthy reason for not having too great a multiplicity of gravity zones within a country, apart from a reduction in bureaucracy, is to maximize the potential for verification at factory, or distributor in the case of imported equipment. There are particular inefficiencies in verifying equipment at the place of use, and it is economic to limit such verification as far as possible. It is appreciated of course that some equipment can only be verified at the place of use by nature of its design. Factory verification confers certain economic advantages as detailed below.

The advantages of factory verification and disadvantages of place of use verification

Factory verification enables a weights and measures inspector to verify on a batch basis which is far more cost effective than visiting a place of use just to stamp one machine. Taking travelling time into account it is probable that end user verification is at least 10 times more expensive, and in the final analysis this extra cost has to be paid for by the owners of the scales, and hence the buying public.

Although verification officers throughout a country will be verifying to the same criteria, in practice there can be problems particularly if a weights and measures inspector is not too familiar with a specific piece of equipment. The factory and probably the distributor will have available certified test weights. This is of particular assistance to the inspector for higher capacity machines. Transporting weights to end user locations can significantly add to verification costs. A further consideration is that the benefits of self verification by manufacturer, which is now being introduced in some countries, will be largely dissipated if a manufacturer can only self verify instruments that are to be used in the limited gravity zone in which the manufacturer's factory is situated. Extending the size of gravity zones will maximize the amount of production that can be verified at the factory.

The above cost saving factors should not be ignored. A proliferation of small gravity zones considerably adds to regulatory costs which eventually have to be paid for by the buying public who we are in the business of protecting.

However, perhaps my argument is a little one sided as place of use verification does completely assure that an instrument is within verification tolerances and excludes any possibility of unjust weighing. In some countries without an indigenous manufacturing base it is probable that the weights and measure service is more organised for local end user verification as against batch verification at an importers premises but then these factors are rather separate from the theme of gravity.

Conclusion

This paper has highlighted the salient facts concerning the irritation of gravity variation. My comments, I hope, have not upset those who have detailed schemes to ensure honest weight. I have looked at the problems in a pragmatic manner and may be my thoughts will be thought provoking particularly to representatives from countries who may have onerous restrictive regulations and to those who have no controls at all in recognition of the force that keeps us glued to planet earth.

A NEW WEIGHBRIDGE TEST UNIT for HAMPSHIRE COUNTY COUNCIL

by Rodney C. GOLDUP

Deputy County Trading Standards Officer,
Hampshire County Council, Winchester, England

In early 1990 the Trading Standards Department of Hampshire County Council, Winchester, England, took delivery of a new weighbridge test unit. This short article sets out the technical specification which may assist other departments likely to be faced with a similar purchase in the near future.

All of Hampshire County Council's vehicles are owned by the Transport Management Organisation, a section within the Commercial Services Department of that Council and vehicles are then leased to user departments. Early discussions with the T.M.O. agreed a maximum budget of £120 000 for a new vehicle and in October 1989 a working party was set up to decide upon the vehicle's specification. 38 tonnes with forklift operation was quickly agreed as the basic specification, with the remaining parameters designed around that fundamental decision.

The various major components of the Unit will be replaced at differing intervals; the forklift will be replaced after 7 years, the tractor unit after 10 years and the trailer after 20 years. With legislative changes possible during these time scales, 44 tonnes design weight was specified and indeed, the finished vehicle has since been tested at the Chobham, Surrey test track at 44 tonnes with entirely satisfactory results. Whilst this specification has resulted in a very large vehicle, the tractor unit has twin drive axles and the trailer is fitted with a steering (and lifting) third axle, both of which help to make the vehicle very manoeuvrable. The twin drive axles are also fitted with locking differentials which will enable the vehicle to have traction in all situations including lime, sand and gravel quarries.

The primary method of operation is by forklift, which has an unladen weight of 5 tonnes and is capable of carrying 3×1 tonne weights. This allows much faster operation and no longer requires the use of other staff to manhandle weights. The block weights (Fig. 1) are particularly advantageous when testing axle weighers and

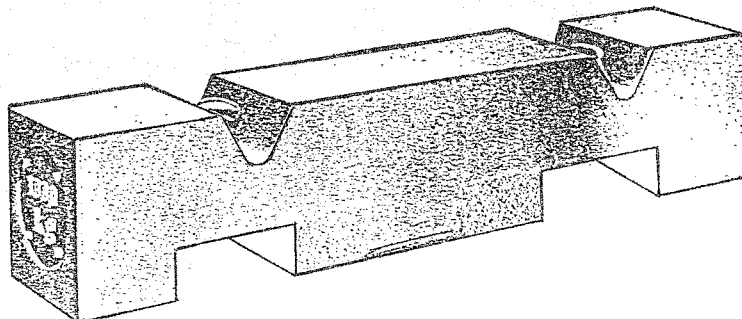

Fig. 1 — 1 000 kg block weight
Length 1 670 mm, Width 285 mm, Height 360 mm
No. of lifting bars 2, No. of slots 2
Slot width 300 mm, Slot height 120 mm

are of sufficient length to straddle railway lines on rail weighbridges. The weights are usually off-loaded from each side of the trailer by forklift, but where necessary the hoist may be used, which is capable of not only off-loading to each side but also to the rear of the trailer.

The trailer has the facility to carry 18×1 tonne weights, although fewer are currently loaded to enable the vehicle to stay within the maximum 38 tonnes United Kingdom limit. Also carried is a half tonne roller weight and another half tonne of 20 kg blocks. The lifting third trailer axle reduces the wheel base to under 12 meters to allow this common size of plate to accommodate the complete vehicle.

The calibration of the 1 tonne block weights is by use of an Avery 32 N 52. The Avery is initially calibrated by use of a cradle and 20 kg weights which have in turn been calibrated using the F1 Hampshire Local Standard and a Sartorius 5788 MP8 balance. Once the initial calibration of the Avery is complete a 1 tonne block transfer standard is weighed. This transfer standard is then re-checked between every two test weights to ensure confidence in the repeatability of the Avery machine. Both machines have been fitted with a gantry system so that any weights suspended on the weighing mechanism invariably exert their force in an identical position.

Hampshire makes extensive use of its weighbridge test unit and hires it to some seven other authorities. The new unit (Fig. 2) came into operation during April, 1990 and has seen use in Hampshire and most of those other authorities, providing an effective and more efficient service.

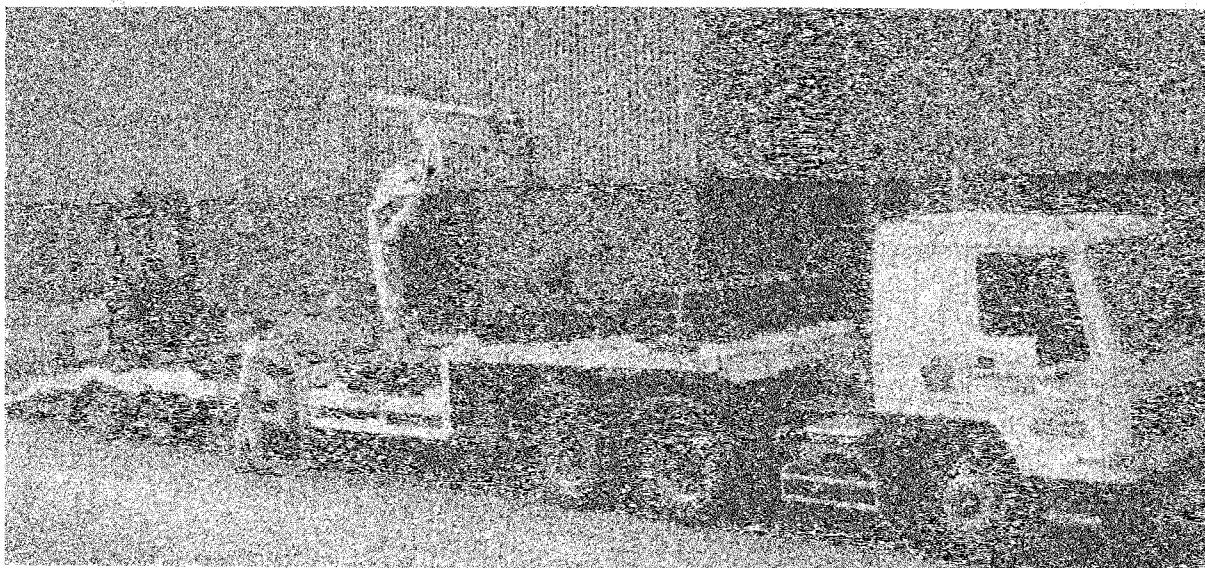

Fig. 2 — The complete test unit comprising tractor unit with hoist, trailer and forklift

Specification of the components of the Hampshire test unit

TRACTOR UNIT

Volvo Intercooler 320 FL10 6 × 4
Gross train weight design 47 000 kg
Twin drive rear axles with diff-lock
Turning circle 12.730 m

TRAILER

Purpose built by Andover Trailers SFCL 38
Gross train weight design 44 000 kg
Three axle, air suspension. Third axle both steering and capable of lifting

WEIGHTS

Manufactured by James W Shenton Ltd.
Hampshire design length 1 670 mm
Width 285 mm, Height 355 mm
1 tonne each with adjustment box
Suitable for lifting by both forklift and hoist

FORKLIFT

Lancer Boss MH 35
Unladen weight just under 5 000 kg
Carrying capacity 3 500 kg
Street legal
Engine Perkins Diesel

HOIST

Pesci Hydraulic loader SP90 with jack legs
3 stage 1.8 m to 6 m radius
Manual extension to 7.7 m
P.T.O. fitted to Volvo tractor unit

WEIGHT CALIBRATION

Sartorius 5788 MP8
Electronic force balance
Capacity: 30 kg
Discrimination: Digital 0.01 g
Use: Calibration of 50 × 20 kg weights and cradle

Avery 32 N 52
Pipe lever platform machine type
Comparator with loose weights resistant and projected readout
Capacity: 1 tonne
Discrimination: > 5 g/mm analogue
Use: Calibration of 1 tonne blockweights

EUROPEAN COOPERATION IN THE FIELD OF TESTING

A survey paper on the various European organisations or associations more or less closely involved in metrology was published in Bulletin de l'OIML No. 106, March 1987. Since then two new metrology associations were created: EUROMET (see objectives in Bulletin de l'OIML No. 109, Dec. 1987) and WELMEC (see objectives in Bulletin de l'OIML No. 120, Sept. 1990).

Cooperation in accreditation of test laboratories is the subject of another joint forum, the Western European Accreditation Cooperation (WELAC), created in December 1989 and which presently comprises 14 countries out of those belonging to the European Economic Community or to the European Free Trade Association. The plan of activities comprises laying down guidelines and standards for the activities of accreditation bodies, establishing cooperation on comparative testing and training of assessors.

The testing of materials and products in general is the subject of two more recently created new organisations: the European Organization for Testing and Certification (EOTC) which basically comprises delegations from national standardization, quality control and certification bodies; and EUROLAB which comprises delegates from public and private testing and analytical laboratories. The objectives of these new organisations are described below*.

THE EUROPEAN ORGANIZATION FOR TESTING AND CERTIFICATION (EOTC)

The European Organization for Testing and Certification (EOTC) was founded on 25 April 1990 through the signature of a Memorandum of Understanding by the Commission of the European Communities, the EFTA Secretariat and CEN/CENELEC, the Joint European Standards Institution. The new Organization is headed by Dr Henrique MACHADO JORGE, EOTC Director Designate, who has taken up his duties in September.

EOTC's mission is to encourage, foster and manage the development of European certification systems and of mutual recognition agreements for test reports and certificates on the basis of coherent principles and processes (EN 45000/EN 29000) which will attract the confidence of all interested parties.

The founding of EOTC is the first concrete achievement following the EC Internal Market Council's Resolution of 21 December 1989 concerning a Global Approach to Testing and Certification.

However, the origins of EOTC go back some years. It was first suggested in 1986 that a new organization was needed to coordinate private sector mutual recognition agreements in Europe such that they should be operationally transparent and be based on principles of quality in order to gain market acceptability and thus help eliminate costly repetitive testing as products crossed frontiers.

The Symposium organized by the Commission of the European Communities in June 1988 provided an opportunity to put this to the consumer and trade union representatives, as well as the professional conformity assessment communities and governments, effectively endorsed the creation of what is now known as EOTC against the guiding principles of openness, representivity and common operating criteria.

The EOTC infrastructure, developed to fulfil these guiding principles, envisages the creation of Sector Committees covering large areas of European industrial activity, with national delegations representing manufacturers, users, and third parties, and in association with those Sector Committees, the Agreement Groups themselves (EOTC's power-house) composed of those who have committed themselves to direct participation in a European certification system or mutual recognition agreement.

Complementing the Sector Committees and the Agreement Groups will be the Specialized Committees, composed of generally recognized experts, whose key function will be to provide

* Reproduced from Eurolab Newsletter No. 1, October 1990.

technical expertise in specialized questions of a horizontal nature. This advice may also be required in the implementation of EOTC's basic technical instruments, such as the EN 45000 and EN 29000 series.

The EOTC infrastructure envisages the possibility of Specialized Committees operating in the disciplines of calibration, testing, certification, quality assurance, and inspection.

The last element in the EOTC infrastructure will be the EOTC Council itself. Composed of representatives of the participating Sector and Specialized Committees plus representatives of the eighteen national conformity assessment communities, European industry, consumers, trade unions, together with representatives of the signatories, the EOTC Council will have the key role of ensuring that the EOTC guiding principles of openness, representivity and technical integrity are maintained across the whole EOTC infrastructure.

In the short time since EOTC's foundation, an ad-hoc Steering Group has been formed, composed of the signatories and representatives of the interested parties, to review actions necessary to achieve a properly constituted EOTC Council. The aim is for the Council to meet by the end of this year. The Steering Group will also review criteria for the development of Sector Committees and in this area several groupings are coming together into fields of common interest to provide the nuclei of possible future Sector Committees. The industrial areas covered by these fields of common interests include the electrotechnical, medical devices, IT, chemical product, iron and steel, aerospace, fire and security, gas, water supply, construction products and machinery sectors.

Whether such fields of interest yield Section Committees in themselves, or will be subsumed into others, still needs further development, but it is nevertheless encouraging that such diverse industrial interests wish to enter the EOTC partnership, and contacts are being established with these interests to ensure continuity.

Dialogue will also be opened shortly with European organizations concerned with specific horizontal aspects of conformity assessment to discuss with them the most appropriate liaison between them and the EOTC structure, with a view to their potential contribution to the Specialized Committees, once need for such horizontal technical expertise has been demonstrated.

The strict timetable imposed the EOTC M.O.U. requires that the ad-hoc Steering Group take all actions required of it to allow the first EOTC Council to take place by the end of 1990. From then, until the end of 1992, the EOTC Council will review all the initiatives taken, ensure coherence in the developing infrastructure, and lay down guidelines for future activity in association and consultation with the signatories.

Thereafter, EOTC is intended to operate in its mature stage, by providing an instrument of quality and confidence to those who wish to use it.

EUROLAB

CREATION

EUROLAB was created on April 27, 1990 in Brussels by the signature of a Memorandum of Understanding by Delegations representing the public and private testing and analytical laboratories of 16 countries belonging to the European Economic Community or to the European Free Trade Association.

OBJECTIVES

- to complement the existing national facilities in order to provide, at the European level, an organized interface between the testing community and all other parties concerned by testing activities,
- to facilitate the technical cooperation between laboratories and other relevant organizations in order to accelerate the development and harmonization of test methods, and their unified implementation thereafter,
- to promote the mutual acceptance of test results by, inter alia, the building of confidence, the development of quality assurance and traceability in testing, and the implementation of the EN 45000 series standards,
- to provide the necessary expertise in the field of testing to the European Organization for Testing and Certification (EOTC).

ACTIVITIES

- identification of areas for the development of scientific and technical cooperation,
- promotion and facilitation of cooperative research and establishment of references for traceability, in close connection with existing organizations,
- exchange of information,
- cooperation for the development and interpretation of test methods, as a contribution to the development of EN standards,
- information and organization of interlaboratory test comparisons and proficiency testing,
- promotion of quality assurance in laboratories, implementation and improvement of the EN 45000 series standards,
- cooperation between laboratories and accreditation bodies,
- provision of the technical infrastructure for the conclusion and maintenance of recognition arrangements between laboratories; EUROLAB has however no power to conclude or operate such agreements, this being the responsibility of the parties legally involved.

At its first General Assembly EUROLAB decided to give priority to:

- the identification of areas for setting up specific cooperations, without duplicating with existing European organizations which, have been invited to join Eurolab.
- the inventory of the various international research programmes (EEC and others), interesting EUROLAB,
- the organization of an European Symposium on quality assurance in testing laboratories,
- the inventory of intercomparison programmes open to European laboratories.

COMPOSITION

The EUROLAB General Assembly is composed of:

- two delegates by country members of the EEC or EFTA representing the laboratories and designated at the national level by an identified mechanism ensuring their representativity of both the private and the public sectors; the EUROLAB M.O.U. was signed by the following national delegations: Austria, Belgium, Denmark, Germany, Finland, France, Iceland, Ireland, Italy, the Netherlands, Norway, Portugal, Spain, Sweden, Switzerland, United Kingdom. Greece will have signed before the second General Assembly,
- in an observer capacity, representatives of European organizations having an interest or a connection with testing: EEC — European Economic Commission, EFTA — European Free Trade Association, CEN — European Committee for Standardization, CENELEC — European Committee for Electrotechnical Standardization, CECC — European Confederation of Inspection Organizations, EGOLF — European Group of Official Laboratories for Fire Testing, EURACHEM — Organization for Analytical Chemistry in Europe, EUROMEDTEST — Organization of European Laboratories Testing Medical Devices, EUROMET — European Collaboration on Measurement Standards, NORDTEST — Testing Organization of the Nordic Countries, WECC — Western European Calibration Cooperation, WELAC — Western European Laboratory Accreditation Cooperation.

INFORMATIONS

ETATS MEMBRES — MEMBER STATES

La République Fédérale d'Allemagne et la République Démocratique Allemande se sont officiellement unifiées le 3 octobre dernier. Il y a donc dorénavant, l'Allemagne, membre de l'OIML, dont le représentant auprès du Comité est le Professeur KOCHSIEK, qui était jusqu'alors Membre du CIML pour la République Fédérale d'Allemagne.

Les activités techniques qu'assumait jusqu'alors la République Démocratique Allemande en tant que membre de l'OIML sont dans leur ensemble reprises par l'Allemagne et s'ajoutent à celles qui étaient assurées par la République Fédérale d'Allemagne.

The Federal Republic of Germany and the German Democratic Republic were officially united on 3 October 1990. There will thus from then on only be one Germany for which the representative is Professor M. KOCHSIEK who was the CIML Member of the Federal Republic of Germany.

The technical activities with the German Democratic Republic handled as Member of OIML are fully taken over by Germany in addition to those which were handled by the Federal Republic of Germany.

MEMBRES DU COMITE — CIML MEMBERS

ROYAUME-UNI — Le Dr Seton BENNETT vient d'être nommé Directeur et Chef Exécutif du National Weights and Measures Laboratory et représentant du Royaume-Uni auprès du Comité International de Métrologie Légale, en remplacement du Dr P. CLAPHAM qui, au printemps dernier, avait été nommé Directeur du National Physical Laboratory.

Nous rappelons que le Dr S. BENNETT est également Président de WELMEC (dont le Vice-Président est Monsieur J. BASTEN, Membre du CIML, Pays-Bas).

SUISSE — Le Dr P. KOCH a pris sa retraite de Vice-Directeur de l'Office Fédéral de Métrologie et a donc cessé ses fonctions de représentant de la Suisse auprès du Comité International de Métrologie Légale.

Le nouveau Membre Suisse de notre Comité est le Dr O. PILLER, Directeur de l'Office.

UNITED KINGDOM — Dr Seton BENNETT has recently been nominated Director and Chief Executive of the National Weights and Measures Laboratory and representative for the United Kingdom within the International Committee of Legal Metrology succeeding Dr P. CLAPHAM who last spring was nominated Director of the National Physical Laboratory.

We remind you the Dr S. BENNETT is also President of WELMEC (of which the Vice-President is Mr J. BASTEN, CIML Member of the Netherlands).

SWITZERLAND — Dr P. KOCH has retired as Vice-Director of the Federal Office of Metrology and thus ceased to represent Switzerland within the International Committee of Legal Metrology.

The new Swiss Member of CIML is Dr O. PILLER, Director of the Federal Office of Metrology.

QUELQUES EVENEMENTS A VENIR — SOME COMING EVENTS

- 12-14 mars 1991
March
- 9th International Zurich Symposium and technical exhibition on electromagnetic compatibility
- Information: EMC Zurich 91, ETH Zentrum-IKT, 8092 Zurich, Switzerland
- 14-15 mai 1991
May
- Flow Measurement in Science and Industry, London, U.K.
- Information: Carol Le Plar, IBC Technical Services Ltd, Bath House, 56 Holborn Viaduct, London EC1A 2EX, U.K.
- 27-31 mai 1991
May
- 6th International Precision Engineering Seminar and 2nd International Conference on Ultra-Precision in Manufacturing Engineering, Braunschweig, Germany
- Information: IPES 6/UMZ Office, PTB, Bundesallee 100, Postfach 3345, 3300 Braunschweig, Germany
- 2-14 juin 1991
June
- Properties of Engineering Materials: Metrology and Standards, Weybridge, Surrey, U.K.
- Information: B.E. Larcombe, MISU, Building 1, National Physical Laboratory, Teddington, Middlesex TW11 OLW, U.K.
- 2-11 juillet 1991
July
- 22nd Session of Commission Internationale d'Eclairage (CIE), Melbourne
- Information: CIE 22nd session, Australian Road Research Board, PO Box 156, Nunawading VIC 3131, Australia
- 5-10 septembre 1991
- 12th IMEKO World Congress, Beijing, China
- Information: The Secretariat of IMEKO XII, c/o Chinese Society for Measurement, P.O. Box 1413, Beijing 100013, China
- 12-14 septembre 1991
- 8th International Symposium on Artificial Intelligence Based Measurement and Control (IMEKO TC 7), Kyoto, Japan
- Information: Prof. Komyo Kariya, Department of Electrical Engineering, Ritsumeikan University, 56-1 Tojiin-kita, Kita-ku, Kyoto 603, Japan
- 22-25 septembre 1991
- 5th Conference on Sensors and their Applications, Edinburgh, U.K.
- Information: Meetings Office, The Institute of Physics, 47 Belgrave Square, London SW1X 8QX, U.K.

REUNIONS OIML MEETINGS

Groupes de travail <i>Working Groups</i>	Dates <i>Date</i>	Lieux <i>Place</i>
SP 7 Mesure des masses <i>Measurement of mass</i>	28 Jan.-1er Févr./Feb. 1991	BRAUNSCHWEIG ALLEMAGNE/ GERMANY
SP 7-Sr 4 Instruments de pesage à fonctionnement non automatique <i>Non-automatic weighing instruments</i>		
SP 5S-Sr 12 Mesurage massique direct en statique des quantités de liquides <i>Static direct mass measurement of quan- tities of liquids</i>	16-17 Mai/May 1991 (provisoire/provisional)	TEDDINGTON ROYAUME-UNI/ UNITED KINGDOM
SP 7-Sr 5 Instruments de pesage à fonctionnement automatique <i>Automatic weighing instruments</i>	20-24 Mai/May 1991	TEDDINGTON ROYAUME-UNI/ UNITED KINGDOM

Conseil de la Présidence <i>Presidential Council</i>	11-13 Fév./Feb. 1991	BIML, PARIS
26e réunion du Comité International de Métrologie Légale <i>26th Meeting of International Committee of Legal Me- trology</i>	7-9 Octobre 1991	PARIS

Note: Liste à jour fin novembre 1990
List as per end November 1990

PUBLICATIONS

- Vocabulaire de métrologie légale 1978
Vocabulary of legal metrology
- Vocabulaire international des termes fondamentaux et généraux de métrologie 1984
International vocabulary of basic and general terms in metrology

RECOMMANDATIONS INTERNATIONALES

INTERNATIONAL RECOMMENDATIONS

- | | Edition |
|---|---------|
| R 1 — Poids cylindriques de 1 g à 10 kg (de la classe de précision moyenne)
<i>Cylindrical weights from 1 g to 10 kg (medium accuracy class)</i> | 1973 |
| R 2 — Poids parallélépipédiques de 5 à 50 kg (de la classe de précision moyenne)
<i>Rectangular bar weights from 5 to 50 kg (medium accuracy class)</i> | 1973 |
| R 4 — Fioles jaugées (à un trait) en verre
<i>Volumetric flasks (one mark) in glass</i> | 1970 |
| R 5 — Compteurs de liquides autres que l'eau à chambres mesureuses
<i>Meters for liquids other than water with measuring chambers</i> | 1981 |
| R 6 — Dispositions générales pour les compteurs de volume de gaz
<i>General provisions for gas volume meters</i> | 1989 |
| R 7 — Thermomètres médicaux (à mercure, en verre, avec dispositif à maximum)
<i>Clinical thermometers (mercury-in-glass, with maximum device)</i> | 1978 |
| R 9 — Vérification et étalonnage des blocs de référence de dureté Brinell
<i>Verification and calibration of Brinell hardness standardized blocks</i> | 1970 |
| R 10 — Vérification et étalonnage des blocs de référence de dureté Vickers
<i>Verification and calibration of Vickers hardness standardized blocks</i> | 1970 |
| R 11 — Vérification et étalonnage des blocs de référence de dureté Rockwell B
<i>Verification and calibration of Rockwell B hardness standardized blocks</i> | 1970 |
| R 12 — Vérification et étalonnage des blocs de référence de dureté Rockwell C
<i>Verification and calibration of Rockwell C hardness standardized blocks</i> | 1970 |
| R 14 — Saccharimètres polarimétriques
<i>Polarimetric saccharimeters</i> | 1978 |
| R 15 — Instruments de mesure de la masse à l'hectolitre des céréales
<i>Instruments for measuring the hectolitre mass of cereals</i> | 1970 |
| R 16 — Manomètres des instruments de mesure de la tension artérielle (sphygmo-manomètres)
<i>Manometers for instruments for measuring blood pressure (sphygmomanometers)</i> | 1970 |

R 18	— Pyromètres optiques à filament disparaissant <i>Visual disappearing filament pyrometers</i>	1989
R 20	— Poids des classes de précision E_1 E_2 F_1 F_2 M_1 de 50 kg à 1 mg <i>Weights of accuracy classes E_1 E_2 F_1 F_2 M_1 from 50 kg to 1 mg</i>	1973
R 21	— Taximètres <i>Taximeters</i>	1973
R 22	— Tables alcoométriques internationales <i>International alcoholometric tables</i>	1975
R 23	— Manomètres pour pneumatiques de véhicules automobiles <i>Tyre pressure gauges for motor vehicles</i>	1973
R 24	— Mètre étalon rigide pour agents de vérification <i>Standard one metre bar for verification officers</i>	1973
R 25	— Poids étalons pour agents de vérification <i>Standard weights for verification officers</i>	1977
R 26	— Seringues médicales <i>Medical syringes</i>	1973
R 27	— Compteurs de volume de liquides (autres que l'eau). Dispositifs complémentaires <i>Volume meters for liquids (other than water). Ancillary equipment</i>	1973
R 29	— Mesures de capacité de service <i>Capacity serving measures</i>	1973
R 30	— Mesures de longueur à bouts plans (calibres à bouts plans ou cales-étalons) <i>End standards of length (gauge blocks)</i>	1981
R 31	— Compteurs de volume de gaz à parois déformables <i>Diaphragm gas meters</i>	1989
R 32	— Compteurs de volume de gaz à pistons rotatifs et compteurs de volume de gaz à turbine <i>Rotary piston gas meters and turbine gas meters</i>	1989
R 33	— Valeur conventionnelle du résultat des pesées dans l'air <i>Conventional value of the result of weighing in air</i>	1973
R 34	— Classes de précision des instruments de mesurage <i>Accuracy classes of measuring instruments</i>	1974
R 35	— Mesures matérialisées de longueur pour usages généraux <i>Material measures of length for general use</i>	1985
R 36	— Vérification des pénétrateurs des machines d'essai de dureté <i>Verification of indenters for hardness testing machines</i>	1977
R 37	— Vérification des machines d'essai de dureté (système Brinell) <i>Verification of hardness testing machines (Brinell system)</i>	1977
R 38	— Vérification des machines d'essai de dureté (système Vickers) <i>Verification of hardness testing machines (Vickers system)</i>	1977

R 39	— Vérification des machines d'essai de dureté (systèmes Rockwell B, F, T - C, A, N) <i>Verification of hardness testing machines (Rockwell systems B, F, T - C, A, N)</i>	1977
R 40	— Pipettes graduées étalons pour agents de vérification <i>Standard graduated pipettes for verification officers</i>	1977
R 41	— Burettes étalons pour agents de vérification <i>Standard burettes for verification officers</i>	1977
R 42	— Poinçons de métal pour agents de vérification <i>Metal stamps for verification officers</i>	1977
R 43	— Fioles étalons graduées en verre pour agents de vérification <i>Standard graduated glass flasks for verification officers</i>	1977
R 44	— Alcoomètres et aréomètres pour alcool et thermomètres utilisés en alcoométrie <i>Alcoholometers and alcohol hydrometers and thermometers for use in alcoholometry</i>	1985
R 45	— Tonneaux et futailles <i>Casks and barrels</i>	1977
R 46	— Compteurs d'énergie d'électricité active à branchement direct (de la classe 2) <i>Active electrical energy meters for direct connection (class 2)</i>	1978
R 47	— Poids étalons pour le contrôle des instruments de pesage de portée élevée <i>Standard weights for testing of high capacity weighing machines</i>	1978
R 48	— Lampes à ruban de tungstène pour l'étalonnage des pyromètres optiques <i>Tungsten ribbon lamps for calibration of optical pyrometers</i>	1978
R 49	— Compteurs d'eau (destinés au mesurage de l'eau froide) <i>Water meters (intended for the metering of cold water)</i>	1977
R 50	— Instruments de pesage totalisateurs continus à fonctionnement automatique <i>Continuous totalising automatic weighing machines</i>	1980
R 51	— Trieuses pondérales de contrôle et trieuses pondérales de classement <i>Checkweighing and weight grading machines</i>	1985
R 52	— Poids hexagonaux. Classe de précision ordinaire de 100 g à 50 kg <i>Hexagonal weights. Ordinary accuracy class, from 100 g to 50 kg</i>	1980
R 53	— Caractéristiques métrologiques des éléments récepteurs élastiques utilisés pour le mesurage de la pression. Méthodes de leur détermination <i>Metrological characteristics of elastic sensing elements used for measurement of pressure. Determination methods</i>	1982
R 54	— Echelle de pH des solutions aqueuses <i>pH scale for aqueous solutions</i>	1981
R 55	— Compteurs de vitesse, compteurs mécaniques de distances et chronotachygraphes des véhicules automobiles - Réglementation métrologique <i>Speedometers, mechanical odometers and chronotachographs for motor vehicles. Metrological regulations</i>	1981
R 56	— Solutions-étalons reproduisant la conductivité des électrolytes <i>Standard solutions reproducing the conductivity of electrolytes</i>	1981
R 57	— Ensembles de mesurage de liquides autres que l'eau équipés de compteurs de volumes. Dispositions générales <i>Measuring assemblies for liquids other than water fitted with volume meters. General provisions</i>	1982

R 58	— Sonomètres <i>Sound level meters</i>	1984
R 59	— Humidimètres pour grains de céréales et graines oléagineuses <i>Moisture meters for cereal grains and oilseeds</i>	1984
R 60	— Réglementation métrologique des cellules de pesée <i>Metrological regulations for load cells</i>	(*)
R 61	— Doseuses pondérales à fonctionnement automatique <i>Automatic gravimetric filling machines</i>	1985
R 62	— Caractéristiques de performance des extensomètres métalliques à résistance <i>Performance characteristics of metallic resistance strain gauges</i>	1985
R 63	— Tables de mesure du pétrole <i>Petroleum measurement tables</i>	1985
R 64	— Exigences générales pour les machines d'essai des matériaux <i>General requirements for materials testing machines</i>	1985
R 65	— Exigences pour les machines d'essai des matériaux en traction et en compression <i>Requirements for machines for tension and compression testing of materials</i>	1985
R 66	— Instruments mesureurs de longueurs <i>Length measuring instruments</i>	1985
R 67	— Ensembles de mesurage de liquides autres que l'eau équipés de compteurs de volumes. Contrôles métrologiques <i>Measuring assemblies for liquids other than water fitted with volume meters. Metrological controls</i>	1985
R 68	— Méthode d'étalonnage des cellules de conductivité <i>Calibration method for conductivity cells</i>	1985
R 69	— Viscosimètres à capillaire, en verre, pour la mesure de la viscosité cinématique <i>Glass capillary viscometers for the measurement of kinematic viscosity</i>	1985
R 70	— Détermination des erreurs de base et d'hystérésis des analyseurs de gaz <i>Determination of intrinsic and hysteresis errors of gas analysers</i>	1985
R 71	— Réservoirs de stockage fixes. Prescriptions générales <i>Fixed storage tanks. General requirements</i>	1985
R 72	— Compteurs d'eau destinés au mesurage de l'eau chaude <i>Hot water meters</i>	1985
R 73	— Prescriptions pour les gaz purs CO, CO ₂ , CH ₄ , H ₂ , O ₂ , N ₂ et Ar destinés à la préparation des mélanges de gaz de référence <i>Requirements concerning pure gases CO, CO₂, CH₄, H₂, O₂, N₂ and Ar intended for the preparation of reference gas mixtures</i>	1985
R 74	— Instruments de pesage électroniques <i>Electronic weighing instruments</i>	1988
R 75	— Compteurs d'énergie thermique <i>Heat meters</i>	1988

- R 76 — Instruments de pesage à fonctionnement non automatique
Non-automatic weighing instruments
Partie 1: Exigences métrologiques et techniques - Essais 1988
Part 1: Metrological and technical requirements - Tests
Partie 2: Rapport d'essai de modèle 1988
Part 2: Pattern evaluation report
- R 77 — Ensembles de mesurage de liquides autres que l'eau équipés de compteurs de volumes. Dispositions particulières relatives à certains ensembles
Measuring assemblies for liquids other than water fitted with volume meters. Provisions specific to particular assemblies 1989
- R 78 — Pipettes Westergren pour la mesure de la vitesse de sédimentation des hématies
Westergren tubes for measurement of erythrocyte sedimentation rate 1989
- R 79 — Etiquetage des préemballages 1989
Information on package labels
- R 80 — Camions et wagons-citernes 1989
Road and rail tankers
- R 81 — Dispositifs et systèmes de mesure de liquides cryogéniques (comprend tables de masse volumique pour argon, hélium, hydrogène, azote et oxygène liquides)
Measuring devices and measuring systems for cryogenic liquids (including tables of density for liquid argon, helium, hydrogen, nitrogen and oxygen) 1989
- R 82 — Chromatographes en phase gazeuse pour la mesure des pollutions par pesticides et autres substances toxiques 1989
Gas chromatographs for measuring pollution from pesticides and other toxic substances
- R 83 — Chromatographe en phase gazeuse équipé d'un spectromètre de masse et d'un système de traitement de données pour l'analyse des polluants organiques dans l'eau 1990
Gas chromatograph/mass spectrometer/data system for analysis of organic pollutants in water
- R 84 — Capteurs à résistance thermométrique de platine, de cuivre ou de nickel (à usages techniques et commerciaux) 1989
Resistance-thermometer sensors made of platinum, copper or nickel (for industrial and commercial use)
- R 85 — Jaugeurs automatiques pour le mesurage des niveaux de liquide dans les réservoirs de stockage fixes 1989
Automatic level gauges for measuring the level of liquid in fixed storage tanks
- R 86 — Compteurs à tambour pour alcool et leurs dispositifs complémentaires 1989
Drum meters for alcohol and their supplementary devices
- R 87 — Contenu net des préemballages 1989
Net content in packages
- R 88 — Sonomètres intégrateurs-moyenneurs 1989
Integrating-averaging sound level meters
- R 89 — Electroencéphalographes - Caractéristiques métrologiques - Méthodes et moyens de vérification 1990
Electroencephalographs - Metrological characteristics - Methods and equipment for verification
- R 90 — Electrocardiographes - Caractéristiques métrologiques - Méthodes et moyens de vérification 1990
Electrocardiographs - Metrological characteristics - Methods and equipment for verification

R 91	— Cinémomètres radar pour la mesure de la vitesse des véhicules <i>Radar equipment for the measurement of the speed of vehicles</i>	1990
R 92	— Humidimètres pour le bois - Méthodes et moyens de vérification: exigences générales <i>Wood-moisture meters - Verification methods and equipment: general provisions</i>	1990
R 93	— Frontofocomètres <i>Focimeters</i>	1990
R 95	— Bateaux-citernes - Prescriptions générales <i>Ships' tanks - General requirements</i>	1990
R 96	— Bouteilles récipients-mesures <i>Measuring container bottles</i>	1990
R 97	— Baromètres <i>Barometers</i>	1990
R 98	— Mesures matérialisées de longueur à traits de haute précision <i>High-precision line measures of length</i>	(*)
R 99	— Instruments de mesure des gaz d'échappement des véhicules <i>Instruments for measuring vehicle exhaust emissions</i>	(*)
R 100	— Spectromètres à absorption atomique pour la mesure des polluants métalliques dans l'eau <i>Atomic absorption spectrometers for measuring metal pollutants in water</i>	(*)
R 101	— Manomètres, vacuomètres et manovacuumètres indicateurs et enregistreurs <i>Indicating and recording pressure gauges, vacuum gauges and pressure-vacuum gauges</i>	(*)

DOCUMENTS INTERNATIONAUX

INTERNATIONAL DOCUMENTS

D 1	— Loi de métrologie <i>Law on metrology</i>	1975
D 2	— Unités de mesure légales <i>Legal units of measurement</i>	1978
D 3	— Qualification légale des instruments de mesurage <i>Legal qualification of measuring instruments</i>	1979
D 4	— Conditions d'installation et de stockage des compteurs d'eau froide <i>Installation and storage conditions for cold water meters</i>	1981
D 5	— Principes pour l'établissement des schémas de hiérarchie des instruments de mesure <i>Principles for the establishment of hierarchy schemes for measuring instruments</i>	1982
D 6	— Documentation pour les étalons et les dispositifs d'étalonnage <i>Documentation for measurement standards and calibration devices</i>	1983
D 7	— Evaluation des étalons de débitmétrie et des dispositifs utilisés pour l'essai des compteurs d'eau <i>The evaluation of flow standards and facilities used for testing water meters</i>	1984

- D 8 — Principes concernant le choix, la reconnaissance officielle, l'utilisation et la conservation des étalons 1984
Principles concerning choice, official recognition, use and conservation of measurement standards
- D 9 — Principes de la surveillance métrologique 1984
Principles of metrological supervision
- D 10 — Conseils pour la détermination des intervalles de réétalonnage des équipements de mesure utilisés dans les laboratoires d'essais 1984
Guidelines for the determination of recalibration intervals of measuring equipment used in testing laboratories
- D 11 — Exigences générales pour les instruments de mesure électroniques 1986
General requirements for electronic measuring instruments
- D 12 — Domaines d'utilisation des instruments de mesure assujettis à la vérification 1986
Fields of use of measuring instruments subject to verification
- D 13 — Conseils pour les arrangements bi- ou multilatéraux de reconnaissance des résultats d'essais, approbations de modèles et vérifications 1986
Guidelines for bi- or multilateral arrangements on the recognition of test results, pattern approvals and verifications
- D 14 — Formation du personnel en métrologie légale - Qualification - Programmes d'étude 1989
Training of legal metrology personnel - Qualification - Training programmes
- D 15 — Principes du choix des caractéristiques pour l'examen des instruments de mesure usuels 1986
Principles of selection of characteristics for the examination of measuring instruments
- D 16 — Principes d'assurance du contrôle métrologique 1986
Principles of assurance of metrological control
- D 17 — Schéma de hiérarchie des instruments de mesure de la viscosité des liquides 1987
Hierarchy scheme for instruments measuring the viscosity of liquids
- D 18 — Principes généraux d'utilisation des matériaux de référence certifiés dans les mesurages 1987
General principles of the use of certified reference materials in measurements
- D 19 — Essai de modèle et approbation de modèle 1988
Pattern evaluation and pattern approval
- D 20 — Vérifications primitive et ultérieure des instruments et processus de mesure 1988
Initial and subsequent verification of measuring instruments and processes
- D 21 — Laboratoires secondaires d'étalonnage en dosimétrie pour l'étalonnage des dosimètres utilisés en radiothérapie 1990
Secondary standard dosimetry laboratories for the calibration of dosimeters used in radiotherapy

(*) Publication en cours d'impression/*Publication being printed.*

Note — Ces publications peuvent être acquises au/*These publications may be purchased from* Bureau International de Métrologie Légale, 11, rue Turgot, 75009 PARIS.



ORGANISATION INTERNATIONALE DE MÉTROLOGIE LÉGALE

ETATS MEMBRES

ALGERIE	INDONESIE
ALLEMAGNE	IRLANDE
ARABIE SAOUDITE	ISRAEL
AUSTRALIE	ITALIE
AUTRICHE	JAPON
BELGIQUE	KENYA
BRESIL	LIBAN
BULGARIE	MAROC
CAMEROUN	MONACO
CANADA	NORVEGE
REP. POP. DE CHINE	PAKISTAN
CHYPRE	PAYS-BAS
REP. DE COREE	POLOGNE
REP. POP. DEM. DE COREE	PORTUGAL
CUBA	ROUMANIE
DANEMARK	ROYAUME-UNI DE GRANDE-BRETAGNE ET D'IRLANDE DU NORD
EGYPTE	SRI LANKA
ESPAGNE	SUEDE
ETATS-UNIS D'AMERIQUE	SUISSE
ETHIOPIE	TANZANIE
FINLANDE	TCHECOSLOVAQUIE
FRANCE	TUNISIE
GRECE	U.R.S.S.
HONGRIE	YUGOSLAVIE
INDE	

MEMBRES CORRESPONDANTS

Albanie - Bahrein - Bangladesh - Barbade - Botswana - Burkina Faso - Colombie - Costa Rica - Equateur
Fidji - Ghana - Hong Kong - Irak - Islande - Jordanie - Koweit - Libye - Luxembourg - Malaisie - Mali
Maurice - Mexique - Népal - Nouvelle-Zélande - Oman - Panama - Pérou - Philippines - Sénégal - Seychelles
Syrie - Trinité et Tobago - Turquie - Venezuela

MEMBRES

du

COMITE INTERNATIONAL de METROLOGIE LEGALE

ALGERIE

Membre à désigner par son Gouvernement
Correspondance adressée à
Office National de Métrologie Légale
1, rue Kaddour Rahim Hussein Dey
ALGER

ALLEMAGNE

Mr M. KOCHSIEK
Directeur
Physikalisch-Technische Bundesanstalt,
Bundesallee 100 - Postfach 3345
3300 BRAUNSCHWEIG.
TP 49-531-592 80 10 FAX 49-531-592 40 06
TX 9-52 822 PTB
TG Bundesphysik Braunschweig

ARABIE SAOUDITE

Mr KHALED Y. AL-KHALAF
Director General
Saudi Arabian Standards Organization
P.O. Box 3437
11471 RIYADH
TP 966-1-479 33 32 FAX 966-1-479 30 63
TX 40 16 10 saso sj
TG giasy

AUSTRALIE

Mr J. BIRCH
Executive Director
National Standards Commission,
P.O. Box 282
NORTH RYDE, N.S.W. 2113.
TP 61-2-888 39 22 FAX 61-2-888 30 33
TX AA 23144
TG NATSTANCOM Sydney

AUTRICHE

Mr R. GALLE
Director of the Metrology Service
Gruppe Eichwesen
Bundesamt für Eich- und Vermessungswesen
Postfach 20
Arltasse 35
A-1163 WIEN.
TP 43-222-92 16 27 FAX 43-222-92 44 65
TX 115 468 bevwn

BELGIQUE

Mr H. VOORHOF
Inspecteur Général
Service de la Métrologie
24-26, rue J.A. De Mot
B-1040 BRUXELLES
TP 32-2-233 61 11 FAX 32-2-230 83 00
TX 20 627 COM HAN

BRESIL

Mr D.C. MOCSANYI
Président, INMETRO
Praça Mauah N° 7, 11 Andar
20081 RIO DE JANEIRO
TP 55-21-233 0286 FAX 55-21-223 0178
TX 2134599 IMNQ BR

BULGARIE

Mr V. TZAREVSKI
Vice-Président
Comité de la Qualité auprès du Conseil des
Ministres de la R.P. de Bulgarie
21, rue du 6 Septembre
1000 SOFIA
TP 359-2-8591
TX 22 570 DKS BG
TG techprogress

CAMEROUN

Mr S. NOUMSI
Sous-Directeur des Poids et Mesures
Direction des Prix, Poids et Mesures
Ministère du Développement Industriel
et Commercial
B.P. 501
YAOUNDE
TP 237-22 31 16 et 237-23 26 17
TX 82-68 à Yaoundé

CANADA

Mr R.G. KNAPP
Director, Legal Metrology Branch
Consumer and Corporate Affairs
207, rue Queen
OTTAWA, Ontario K1A OC9
TP 1-613-952 0655 FAX 1-613-952 1736
TX 053 3694

REPUBLIQUE POPULAIRE DE CHINE

Mr BAI JINGZHONG
Deputy Director General
State Bureau of Technical Supervision
P.O. Box 2112
BEIJING 100009
TP 86-1-44 43 04 FAX 86-1-4011016
TX 210209 SBTS CN
TG 1918 Beijing

CHYPRE

Mr G. TSIARTZAZIS
Controller of Weights and Measures
Ministry of Commerce and Industry
NICOSIA
TP 357-2-40 34 41 FAX 357-2-36 61 20
TX 2283 MIN COMIND
TG Mincommind Nicosia

REPUBLIQUE DE COREE

Mr SON BOCK-GILL
Director of Metrology Division
Bureau of Standards
Industrial Advancement Administration
2, Chungang-dong
KWACHON-CITY, KYONGGI-DO 427-010
TP 82-2-503 79 28 FAX 82-2-503 79 41
TG KOREA IAA
TX 28456 FINCEN K

REPUBLIQUE POP. DEM. DE COREE

Mr DJEUNG KI TCHEUL
Directeur de l'Institut Central de Qualité
et de Métrologie auprès du Comité National
de la Science et de la Technologie
Arrondissement de Sadong
PYONGYANG
TG standard

CUBA

Membre à désigner par son Gouvernement
Correspondance adressée à :
Mr Acosta Alemany
Comite Estatal de Normalizacion
Egido 610 e/Gloria and Apodaca
HABANA Vieja
TP 53-7-62-1503, 62-1504, 62-2892
TX 512236 CENDH
TG CEN HAVANA

DANEMARK

Mr Ove E. PETERSEN
Senior Executive Engineer
Division of Metrology
National Agency of Industry and Trade
Tagensvej 135
DK-2200 COPENHAGEN N
TP 45-31-85 10 66 FAX 45-1-81 70 68
TX 15768 INDTRA DK

EGYPTE

Mr M. HILAL
Président,
Egyptian Organization for Standardization
and Quality Control
2 Latin America Street, Garden City
CAIRO.
TP 20-2-26 355
TX 93 296 EOS
TG TAWHID

ESPAGNE

Membre à désigner par son Gouvernement
Correspondance adressée à :
Centro Espanol de Metrologia
c/ del alfar s/n
28760 TRES CANTOS (Madrid)
TP 34-1-803 33 03 FAX 34-1-803 11 78
TX 47254 CEME E

ETATS-UNIS D'AMERIQUE

Mr S.E. CHAPPELL
Chief, Standards Management Program
Office of Standards Services
National Institute of Standards and Technology
Admin. 101, A625
GAITHERSBURG, Maryland 20899
TP 1-301-975 40 24 FAX 1-301-963 28 71
TX 197674 NBS UT

ETHIOPIE

Mr Yohannes AFEWORK
Head of Technical Service
Ethiopian Authority for Standardization
P.O. Box 2310
ADDIS ABABA.
TP 251-1-15 04 00 et 15 04 25
TX 21725 ETHSA ET
TG ETHIOSTAN

FINLANDE

Madame U. LÄHTEENMÄKI
Director of Metrology Department
Technical Inspection Centre
Box 204
SF 00181 HELSINKI
TP 358-0-61 671 FAX 358-0-6167 467
TG TEKTARTOS HKI

FRANCE

Mr Ph. BERTRAN
Sous-Directeur de la Métrologie
S.A.R.S.C.I. Ministère de l'industrie et de l'aménagement
du territoire
30-32, rue Guersant
75833 PARIS Cedex 17
TP 33-1-45 72 85 85 FAX 33-1-45 72 87 57
TX 649 917 F

GRECE

Mr A. DESIS
Technical Officer
Directorate of Weights and Measures
Ministry of Commerce
Canning Sq.
10181 ATHENS
TP 30-1-36 14 168 FAX 30-1-364 26 42
TX 21 67 35 DRAG GR et 21 52 82 YPEM GR

HONGRIE

Mr D. BELEDI
Président, Országos Mérésügyi Hivatal,
P.O. Box 19
H-1531 BUDAPEST
TP 36-1-1567 722
TX 22-4856 OMH
TG HUNGMEETER Budapest

INDE

Mr S. HAQUE
Director, Weights & Measures
Ministry of Food and Civil Supplies
Weights and Measures Unit
12-A, Jam Nagar House
NEW DELHI 110 011
TP 91-11-38 53 44
TX 31 61962 COOP IN
TG POORTISAHAKAR

INDONESIE

Mr G.M. PUTERA
Director of Metrology
Directorate General of Domestic Trade
Departemen Perdagangan
Jalan Pasteur 27
40171 BANDUNG.
TP 62-22-50 597 et 50 695
TX 28 176

IRLANDE

Mr J. LOWE
Assistant Secretary
Department of Industry and Commerce
Frederick Building, Setanta Centre,
South Frederick Street,
DUBLIN 2.
TP 353-1-61 44 44 FAX 353-1-79 57 10
TX 93478
TG TRADCOM Dublin

ISRAEL

Mr A. RONEN
Controller of Weights, Measures and Standards
Ministry of Industry and Trade
P.O.B. 299
JERUSALEM 91002
TP 972-2-27 241

ITALIE

Mr C. AMODEO
Capo dell'Ufficio Centrale Metrico,
Via Antonio Bosio, 15
00161 ROMA.
TP 39-6-348 78 34

JAPON

Mr S. HATTORI
Director General
National Research Laboratory of Metrology
1-4, Umezono 1-Chome, Tsukuba
IBARAKI 305.
TP 81-298-54 41 49 FAX 81-298-54 41 35
TX 03652570 AIST
TG KEIRYOKEN TSUCHIURA

KENYA

Mr P.A. AYATA
Director of Weights and Measures
Weights and Measures Department
Ministry of Commerce
P.O. Box 41071
NAIROBI
TP 254-2-50 46 64/5
TG ASSIZERS, Nairobi

LIBAN

Membre à désigner par son Gouvernement
Correspondance à adresser à
Service des Poids et Mesures,
Ministère de l'Economie et du Commerce,
Rue Al-Sourati, imm. Assaf
RAS-BEYROUTH.
TP -- 34 40 60

MAROC

Mr M. BENKIRANE
Chef de la Division de la Métrologie Légale
Direction de l'Industrie
5, rue Errich, Immeuble A, Quartier Hassan
RABAT.
TP 212-7-51 792
TX 31816 M

MONACO

Mr A. VEGLIA
Ingénieur au Centre Scientifique de Monaco
16, Boulevard de Suisse
MC 98000 MONTE CARLO
TP 33-93-30 33 71

NORVEGE

Mr K. BIRKELAND
Directeur Général
Service National de Métrologie
Postbox 6832 St. Olavs Plass
0130 OSLO 1
TP 47-2-20 02 26 FAX 47-2-20 77 72

PAKISTAN

Mr M. ASAD HASAN
Director
Pakistan Standards Institution
39-Garden Road, Saddar
KARACHI-74400.
TP 92-21-772 95 27
TG PEYASAI

PAYS-BAS

Mr J.A.J. BASTEN
Directeur, IJkwezen bv
Nederlands Meetinstituut nv
Postbus 654
2600 AR DELFT.
TP 31-78 33 23 00 FAX 31-15-61 29 71
TX 38 373 IJKWZ NL

POLOGNE

Mr Z. REFEROWSKI
Vice-Président
Polski Komitet Normalizacji, Miar i Jakosci
ul. Elekoralna 2
00-139 WARSZAWA.
TP 48-22-20 54 34 FAX 48-22-20 66 46
TX 813 642 PKN
TG PEKANIM

PORTUGAL

Mr J.N. CARTAXO REIS
Service de la Métrologie
Instituto Português da Qualidade
Rua Prof. Reinaldo Santos
Lote 1378
1500 LISBOA
TP 351-1-78 61 58 FAX 351-1-78 19 80
TX 65744 METROO P

ROUMANIE

Mr D. STOICHITOIU
Directeur de la Métrologie d'Etat
Commission Nationale de Normalisation,
Métrologie et Qualité
21 blvd Nicolae Balcescu
BUCAREST 1
TP 40-0-13 16 05
TX 011 355 IGS R

ROYAUME-UNI

Mr S. BENNETT
 Director,
 National Weights and Measures Laboratory
 Stanton Avenue
 TEDDINGTON, Middlesex TW 11 OJZ
 TP 44-81-943 72 72 FAX 44-81-943 72 70
 TX 9312131043 (WM G)

SRI LANKA

Mr H.L.R.W. MADANAYAKE
 Deputy Commissioner of Internal Trade
 Measurement Standards and Services Division
 Department of Internal Trade
 101, Park Road
 COLOMBO 5.
 TP 94-1-83 261

SUEDE

Mr R. OHLON
 Ingénieur en Chef, Statens Provningsanstalt.
 P.O. BOX 857
 S-501 15 BORÅS.
 TP 46-33-16 50 00 FAX 46-33-13 55 02
 TX 36252 TESTING S

SUISSE

Mr O. PILLER
 Directeur, Office Fédéral de Métrologie
 Lindenweg 50
 3084 WABERN/BE.
 TP 41-31-59 61 11 FAX 41-31-59 62 10
 TX 912860 TOPO CH
 TG OFMET

TANZANIE

Mr A.H.M. TUKAI
 Commissioner for Weights and Measures
 Weights and Measures Bureau
 Ministry of Industries and Trade
 P.O. Box 313
 DAR ES SALAAM
 TP 64046/64797/64808
 TX 41 689 INDIS

TCHECOSLOVAQUIE

Mr M. CIBAK
 Advisor of the Director
 Czechoslovak Institute of Metrology
 L. Novomeskeho 4
 842 55 BRATISLAVA
 TP 42-7-329 820 et 329 865
 TX 92786 METR
 TG METR BRATISLAVA

TUNISIE

Mr Ali BEN GAID
 Président Directeur Général
 Institut National de la Normalisation
 et de la Propriété Industrielle
 Boîte Postale 23
 1012 TUNIS BELVEDERE
 TP 216-1-785 922 FAX 216-1-781 563
 TX 13 602 INORPI

U.R.S.S.

Mr V.I. PUSTOVOIT
 Vice-Président
 Gosstandart
 Leninsky Prospect 9
 117049 MOSCOU.
 TP — 236 40 44
 TX 411 378 GOST
 TG Moskva-Standart

YUGOSLAVIE

Mr Z.M. MARKOVIC
 Head of International Cooperation
 Federal Bureau of Measures and Precious
 Metals
 Mike Alasa 14
 11000 BEOGRAD.
 TP 38-11-18 37 36
 TX 11 020 YUZMBG

TP = telephone FAX = telecopie (telex)

Les numéros sont en général indiqués pour le régime automatique international à l'exception des numéros qui sont précédés d'un trait.

The call numbers are generally indicated for international automatic dialling except where the local number is preceded by a dash.

TG = telegramme TX = telex

Pour tout télex ou télégramme, il est nécessaire d'indiquer le nom de la personne et sa qualité.
For all telex or telegrams it is necessary to indicate name of person and occupation.

PRESIDENCE

Président K. BIRKELAND, Norvège
Vice-Président S.E. CHAPPELL, U.S.A.
Vice-Président N...

CONSEIL DE LA PRESIDENCE

K. BIRKELAND, Norvège, Président	M. KOCHSIEK, Allemagne
S.E. CHAPPELL, U.S.A., V/Président	R.G. KNAPP, Canada
J. BIRCH, Australie	Ph. BERTRAN, France
BAI JINGZHONG, Rép. Pop. de Chine	S. BENNETT, Royaume-Uni
V.I. PUSTOVOIT, U.R.S.S.	
Le Directeur du Bureau International de Métrologie Légale	

BUREAU INTERNATIONAL DE METROLOGIE LEGALE

Directeur	B. ATHANÉ
Adjoint au Directeur	S.A. THULIN
Adjoint au Directeur	F. PETIK
Ingénieur Consultant	W.H. EMERSON
Ingénieur	E. WEBER
Administrateur	Ph. LECLERCO

MEMBRES D'HONNEUR

J. STULLA-GOTZ, Autriche — Président du Comité
H. MOSER, Allemagne — Membre du Conseil de la Présidence
V. ERMAKOV, U.R.S.S. — Vice-Président du Comité
A.J. van MALE, Pays-Bas — Président du Comité
A. PERLSTAIN, Suisse — Membre du Conseil de la Présidence
W. MUEHE, Allemagne — Vice-Président du Comité
H.W. LIERS, Allemagne — Membre du Conseil de la Présidence

ADRESSES DES SERVICES DES MEMBRES CORRESPONDANTS

ALBANIE

Directeur
Drejtoria e Standardeve dhe e Mjeteve
Matëse (DSMA)
në Komisionin e Planit të Shtetit
TIRANA

BAHREIN

The Responsible of Metrology
Standards and Metrology Section
Ministry of Commerce and Agriculture
P.O. Box 5479
MANAMA

BANGLADESH

Director General
Bangladesh Standards and Testing Institution
116-A, Tejgaon Industrial Area
DHAKA 1208

BARBADE

Director
Barbados National Standards Institution
Culloden Road
St. Michael
BARBADOS W.I.

BOTSWANA

The Permanent Secretary
Division of Weights and Measures
Department of Commerce and Consumer Affairs
Private Bag 48
GABORONE

BURKINA FASO

Direction Générale des Prix
Ministère du Commerce
et de l'Approvisionnement du Peuple
B.P. 19
OUAGADOUGOU

COLOMBIE

Superintendencia de Industria y Comercio
Centro de Control de Calidad y Metrología
Cra. 37 No 52-95, 4° piso
BOGOTA D.E.

COSTA RICA

Oficina Nacional de Normas y Unidades
de Medida
Ministerio de Economía y Comercio
Apartado 10 216
SAN JOSE

EQUATEUR

The Director General
Instituto Ecuatoriano de Normalización
Calle Baquerizo Moreno No 454
entre 6 de Diciembre y Almagro
Casilla No 3999
QUITO

FIDJI

The Chief Inspector of Weights and Measures
Ministry of Economic Development, Planning
and Tourism
Government Buildings
P.O. Box 2118
SUVA

GHANA

Ghana Standards Board
Kwame Nkrumah Conference Centre
(Tower Block - 2nd Bay, 3rd Floor)
P.O. Box M-245
ACCRA

HONG-KONG

Commissioner of Customs and Excise
(Attn. Trading Standards Investigation Bureau)
Tokwawan Market & Government Offices
165, Ma Tau Wei Road
11/F., Kowloon
HONG KONG

IRAK

Planning Board
Central Organization for Standardization
and Quality Control
P.O.B. 13032
Al Jadiria
BAGHDAD

ISLANDE

The Director
Weights and Measures in Iceland
Löggildingarstofan
Sidumula 13
P.O. Box 8114
128 REYKJAVIK

JORDANIE

Directorate of Standards
Ministry of Industry and Trade
P.O. Box 2019
AMMAN

KOWEIT

The Under Secretary
Ministry of Commerce and Industry
Department of Standards and Metrology
Post Box No 2944
KUWAIT

LIBYE

The Director General
National Centre for Standardization
and Metrology
(N.C.S.M.)
P.O. Box 5178
TRIPOLI

LUXEMBOURG

Le Préposé du Service de Métrologie
Administration des Contributions
Rue des Scillas
2529 HOWALD

MALAISIE

The Acting Director of Standards
Standards and Industrial Research Institute of
Malaysia
P.O. Box 35, Shah Alam
SELANGOR

MALI

Le Directeur Général des Affaires Economiques
(Service des Poids et Mesures)
B.P. 201
BAMAKO

MAURICE

The Permanent Secretary
Ministry of Trade and Shipping
(Division of Weights and Measures)
New Government Centre
PORT LOUIS

MEXIQUE

Direccion General de Normas
Secretaria de Comercio y Fomento Industrial
Sistema Nacional de Calibracion
Ave. Puente de Tecamachalco no. 6 - Planta Baja
Lomas de Tecamachalco, Seccion Fuentes
53950 NAUCALPAN DE JUAREZ

NEPAL

The Chief Inspector
Nepal Bureau of Standards and Metrology
P.B. 985
Sundhara
KATHMANDU

NOUVELLE-ZELANDE

The Chief Inspector of Weights and Measures
Ministry of Commerce
P.O. Box 1473
WELLINGTON

OMAN

The Director General
for Specifications and Measurements
Ministry of Commerce and Industry
P.O. Box 550
MUSCAT

PANAMA

Le Directeur
Comision Panamena de Normas Industriales
y Tecnicas
Ministerio de Comercio e Industrias
Apartado 9658
PANAMA 4

PEROU

The Director General
ITINTEC Instituto de Investigacion Tecnologica
Industrial y de Normas Tecnicas
Apartado 145
LIMA 100

PHILIPPINES

The Director
Product Standards Agency
Ministry of Trade and Industry
Trade & Industry Building
361 Sen. Gil J. Puyat Avenue
Makati, Metro Manila
PHILIPPINES 3117

SENEGAL

Monsieur le Directeur
Institut Sénégalais de Normalisation
Ministère du Plan et de la Coopération
DAKAR

SEYCHELLES

The Director
Seychelles Bureau of Standards
P.O. Box 648
VICTORIA

SYRIE

The General Director
The Syrian Arab Organization
for Standardization and Metrology
P.O. Box 11836
DAMASCUS

TRINITE ET TOBAGO

The Director
Trinidad and Tobago Bureau of Standards
P.O. Box 467
PORT OF SPAIN

TURQUIE

Monsieur le Directeur Général
Service du Contrôle de la Qualité et des Mesures
Sanayi ve Ticaret Bakanligi
Ölçüler ve Kalite Kontrol Genel
Müdürlüğü
ANKARA

VENEZUELA

Le Directeur
Direccion General de Tecnologia
Servicio Nacional de Metrologia
Ministerio de Fomento,
Av. Javier Ustariz, Edif. Parque Residencial
Urb. San Bernardino
CARACAS.

